

Lane Code  
CHAPTER 16 CONTENTS

SUBDIVISION AND DIRECTION SIGNS RURAL COMPREHENSIVE PLAN

16.259 Subdivision and Direction Signs.

CLUSTER SUBDIVISIONS RURAL COMPREHENSIVE PLAN

16.260 Cluster Subdivisions.

AUTHORITY TO CHARGE FEES

RURAL COMPREHENSIVE PLAN

16.261 Authority to Charge Fees.

ENFORCEMENT REQUIREMENTS

RURAL COMPREHENSIVE PLAN

16.262 Enforcement Requirements.

ENFORCEMENT

RURAL COMPREHENSIVE PLAN

16.263 Failure to Comply.

TELECOMMUNICATION TOWER STANDARDS

RURAL COMPREHENSIVE PLAN

16.264 Telecommunication Tower Standards.

TRANSPORTATION FACILITIES AND USES RURAL COMPREHENSIVE PLAN

16.265 Transportation Facilities and Uses.

LC 16.280 Goshen Industrial Zones (GI, LI)

Lane Code  
CHAPTER 16 CONTENTS

**SUBDIVISION AND DIRECTION SIGNS RURAL  
COMPREHENSIVE PLAN**

**16.259 Subdivision and Direction Signs.**

- (1) Standards.
  - (a) Subdivision signs announcing the division and improvement of property may be erected within the platted subdivision area as follows:
    - (i) For the first acre or fraction thereof: One sign not exceeding 64 square feet, which may have a surface area on a single-face sign of 64 square feet or a surface area on a double-face sign of 128 square feet.
    - (b) Two directional signs, each being six square feet or less, being either single-or double-faced, may be erected outside the platted subdivision area, not within the public right-of-way.
    - (c) No sign shall be constructed, erected or maintained which:
      - (i) Bears or contains statements, words or pictures of an obscene, indecent or immoral character, such as will offend public morals or decency.
      - (ii) Purports to be or is an imitation of, or resembles an official traffic sign or signal, or which bears the words "STOP," "GO SLOW," "CAUTION," "DANGER," "WARNING" or similar words.
      - (iii) By reason of its size, location, movement, content, coloring or manner of illumination may be confused with or construed as a traffic control device, or which hides from view any traffic of street sign or signal.
      - (iv) Advertises or publicizes an activity, business product or service no longer conducted on the premises upon which such signs are maintained.
      - (v) Carries a message on a rotating or moving part. Only minor decorative parts of signs may move or rotate.
      - (vi) Uses banners, flags, posters, pennants, ribbons, streamers, strings, light bulbs or spinners.
  - (2) Procedure. A request for a permit to erect a sign or signs in accordance with the provisions of this section may be initiated by submitting an application in writing, on a standard form issued by the Planning Director, duly signed by the applicant and filed with the Planning Department. *(Revised by Ordinance No. 7-87, Effective 6.17.87)*

**CLUSTER SUBDIVISIONS RURAL  
COMPREHENSIVE PLAN**

**16.260 Cluster Subdivisions.**

- (1) Purpose. Cluster subdivisions are explicitly permitted and encouraged by various zones as an alternative to standard subdivision development. They are intended to promote a more efficient use of land, retain more land in its natural state, reduce the overall land use impact of the subdivision process and reduce the amount of roads, services and facilities needed to serve a development.
- (2) Applicability. Cluster subdivisions are permitted uses in the following zones: RR-RCP and RA-RCP.
- (3) Permitted Uses.
  - (a) Mobile homes shall only be permitted in a cluster subdivision, if the zone applicable to the subdivision allows mobile homes as a permitted use.
  - (b) Two-family and multiple-family residences are permitted within a cluster subdivision provided they comply with the development standards of this subsection.
- (4) Development Standards.
  - (a) Lot Density.
    - (i) The number of lots intended for dwellings or mobile homes within a cluster subdivision shall not exceed the density of zones and shall be determined by dividing the gross acreage by the minimum area requirement permitted by the zone.

Lane Code  
CHAPTER 16 CONTENTS

(ii) In addition to lots intended for dwellings or mobile homes, a cluster subdivision may include a lot not intended for dwelling or mobile home use and intended for private open space and recreation purposes.

(b) Living Unit Density.

(i) A single living unit shall be considered to be a single-family dwelling, a mobile or one living unit with kitchen facilities and designed for the occupancy of one family, but sharing a common foundation, walls and roof with one or more other units in a duplex or multiple-family dwelling.

(ii) The ultimate number of living units permitted in a cluster subdivision shall be determined by multiplying the number of lots permitted for dwellings or mobile homes by:

(aa) Two, if the zone permits duplexes;

or

(bb) One, if only single-family dwelling or mobile homes are permitted by the

zone.

(iii) A cluster subdivision lot shall be limited to one of the following living units:

(aa) A mobile home.

(bb) A single-family dwelling.

(cc) A two-family dwelling or duplex.

(dd) A multiple-family dwelling.

(c) Setbacks and Lot Coverage.

(i) Except for the setback requirements of the zone for the exterior boundaries of the cluster subdivision, the setback and lot coverage requirements of the zone shall not apply.

(ii) Where cluster subdivision lots intended for dwellings or mobile homes abut a zone which does not permit a cluster subdivision, a special building setback may be established for one or more lots. Special building setback requirements shall be established only for the purposes of reducing potential conflicts relating to fire, traffic, noise or similar human-made or natural hazards, nuisances and for protection of natural resources and open space. The special building setback requirement may consist of, but is not limited to, the setback requirements of the abutting zone which does not permit cluster subdivisions.

(5) Application and Additional Requirements. Cluster subdivisions shall be processed in the same manner and conform to the applicable provisions, standards and procedures as required for subdivisions as provided in LC Chapter 13. *(Revised by Ordinance No. 7-87, Effective 6.17.87)*

**AUTHORITY TO CHARGE FEES  
RURAL COMPREHENSIVE PLAN**

**16.261 Authority to Charge Fees.**

(1) The Department shall have the authority to charge fees for the purposes of defraying expenses involved in processing applications required by this chapter.

(2) All fees are nonrefundable, except in cases when the processing of an application was terminated prior to the incurring of any substantial administrative expenses. Refunds shall be made for the amount of the fee remaining after the subtraction of processing expenses incurred by the Department. *(Revised by Ordinance No. 7-87, Effective 6.17.87)*

**ENFORCEMENT REQUIREMENTS  
RURAL COMPREHENSIVE PLAN**

**16.262 Enforcement Requirements.**

(1) Title, Purpose and Applicability. The provisions of this section shall be known as the Enforcement Requirements. The purpose of these requirements is to ensure compliance with the zoning requirements. These provisions shall apply to the enforcement of the zoning requirements, but shall not be deemed exclusive.

Lane Code  
CHAPTER 16 CONTENTS

(2) Official Action. All officials, Departments and employees of Lane County vested with authority to issue permits, certificates or licenses, shall adhere to and require conformance with the zoning requirements.

(3) Inspection and Right of Entry. Whenever they shall have cause to suspect a violation of any provision of the zoning requirements, or when necessary to investigation of an application for or revocation of any zoning approval under any of the procedures prescribed in this chapter, officials responsible for enforcement or administration of this chapter, or their duly authorized representatives, may enter on any site or into any structure for the purpose of investigation; provided they shall do so in a reasonable manner. No secured building shall be entered without the consent of the owner or occupant, unless under authority of a lawful warrant.

(4) Unauthorized Work. If the Director discovers any person doing or causing to be done any work without the permit required by this chapter, the Director shall notify the person to cease the act or acts, and such person shall cease such acts until a permit is secured, and shall pay for such permit twice the amount of the fee otherwise required.

(5) Stop Work Orders. Whenever any work is being done contrary to provisions of this chapter or an approved Special Use application or other discretionary permit issued pursuant to the requirements of any of the sections of this chapter, or the Director has probable cause to believe that any other provision of the Lane Code is being violated in connection with the project of which the work being performed is a part, the Director may order the work stopped by notice in writing, posted on the project, or served on any person engaged in the doing or causing of such work to be done. Upon the posting or service of notice, all persons engaged in doing or causing the work to be done shall immediately stop such work until authorized by the Director to proceed.

(6) Abatement. Any use which is established, operated, erected, moved, altered, enlarged, painted or maintained contrary to the zoning requirements shall be, and is hereby declared to be, unlawful and a public nuisance and may be abated as such.

(7) Enforcement Official. It shall be the duty of the Director of the Lane County Land Management Division, or said Director's duly authorized representative, to enforce the provisions of this chapter pertaining to land use and to the erection, construction, enlargement, alteration, repair, moving, removal, conversion, demolition, occupancy, equipment, use, height, area and maintenance of buildings or structures in the County. The enactment of this chapter shall not invalidate any prior existing or future prosecutions for violation of the zoning requirements committed under previous applicable County ordinances then in effect.

(8) Legal Proceedings by District Attorney. In addition to the enforcement provisions of this chapter, upon request of the Building Official, the District Attorney or County Counsel may institute any additional proceedings, including, but not limited to, seeking injunctive relief to enforce the provisions of this chapter.

(9) Enforcement by Department of Public Safety. The Director of the Department of Public Safety, or said Director's authorized representatives, shall have the power, upon request of the Building Official, District Attorney or County Counsel, to assist in the enforcement of the provisions of this chapter.

(10) Remedies Cumulative. It is the intent of this chapter that the remedies provided be cumulative and not mutually exclusive. *(Revised by Ordinance No. 7-87, Effective 6.17.87; 1-93, 4.16.93; 4-04, 12.23.04)*

**ENFORCEMENT  
RURAL COMPREHENSIVE PLAN**

**16.263 Failure to Comply.**

Failure to comply with any of the requirements of this chapter may be subject to an administrative civil penalty as provided by LC 5.017. Failure to comply with a condition of an approved Special Use application or other discretionary permit issued pursuant to the requirements of any of the sections of this chapter may also be subject to an administrative civil penalty. Continued failure to comply with this chapter 10 days from the mailing of the notice of the failure to comply by registered or certified mail to the last known address of the alleged responsible person or after personal service, and continued failure to comply after an order has been entered constitutes a separate failure to comply for each day the occurrence continues. The

Lane Code  
CHAPTER 16 CONTENTS

Manager of the Lane County Land Management Division, Department of Public Works, or said Manager's duly authorized representatives, shall have the authority to issue a notice of failure to comply. *(Revised by Ordinance No. 7-87, Effective 6.17.87; 1-93, 4.16.93)*

**TELECOMMUNICATION TOWER STANDARDS  
RURAL COMPREHENSIVE PLAN**

**16.264 Telecommunication Tower Standards.**

(1) Purpose. The provisions of this section are intended to ensure that telecommunication facilities are located, constructed, maintained and removed in a manner that:

- (a) Recognizes the public need for provision of telecommunication facilities;
- (b) Allows appropriate levels of service to be obtained throughout the County;
- (c) Minimizes the number of transmission towers throughout the County;
- (d) Encourages the collocation of telecommunication facilities; and
- (e) Ensures that all telecommunication facilities, including towers, antennas, and ancillary facilities are located and designed to minimize the visual impact on the immediate surroundings and throughout the county. Nothing in this section shall preclude collocation opportunities nor adversely affect multiple use towers. Nothing in this section shall apply to amateur radio antennae, or facilities used exclusively for the transmission of television and radio signals.

(2) Definitions. As used in LC 16.264, the following words and phrases mean:

Ancillary facilities. The buildings, cabinets, vaults, closures and equipment required for operation of telecommunication facilities including but not limited to repeaters, equipment housing, and ventilation and other mechanical equipment.

Antennae. An electrical conductor or group of electrical conductors that transmit or receive radio signals, excluding amateur radio antennae.

Attachment. An antenna or other piece of related equipment affixed to a transmission tower.

Changeout. Reconstruction or replacement of existing collocations or transmission towers with similar equipment, in conformance with LC 16.264(3)(h) below.

Collocation. Placement of an antenna or related telecommunication equipment on an existing structure or building where the antennas and all supports are located on the existing structure or building, not including eligible facilities requests for a modification of an existing tower or base station that does not substantially change the physical dimensions of such tower or base station pursuant to Section 6409(a) of the Spectrum Act.

Provider. A person in the business of designing and/or using telecommunication facilities including cellular radiotelephones, personal communications services, enhanced/specialized mobile radios, and commercial paging services.

Telecommunication Facility. A facility designed and/or used for the purpose of transmitting, receiving, and relaying voice and data signals from antennae, related telecommunication equipment, towers and ancillary facilities. For purposes of this section, amateur radio transmission facilities and facilities used exclusively for the transmission of television and radio signals are not "telecommunication facilities."

Tract. A unit of land comprised of adjacent parcels and lots under the same ownership.

Transmission Tower. The structure, such as a monopole or lattice framework, designed to support transmitting and receiving antennae and related telecommunication equipment. For purposes of this section, amateur radio transmission facilities and facilities used exclusively for the transmission of television and radio signals are not "transmission towers."

(3) Standards applicable to all telecommunication facilities.

(a) Telecommunication facilities shall be limited to the height necessary to provide the service, not to exceed 200 feet in height from ground level.

(b) Based on the existing conditions and vegetation at the site, telecommunication facilities shall be designed and constructed to reduce visibility of the facilities. Nothing in this subsection preempts the coloring requirements of the Federal Aviation Administration or the Oregon Department of Aviation.

Lane Code  
CHAPTER 16 CONTENTS

(i) The transmission tower shall be surfaced in a non-reflective material that minimizes glare and is colored similar to the sky or adjacent background. A light gray shade is appropriate for blending the tower into the sky background.

(ii) The antenna, related telecommunication equipment and ancillary facilities shall be surfaced in non-reflective material to match the transmission tower. If not attached to a transmission tower, they shall be colored similar to the adjacent background.

(c) Consideration shall be given to other sites and equipment that would have less visual impact than those proposed. The applicant shall demonstrate that less intrusive sites and equipment are not available or do not provide the communication coverage necessary to provide the service. Visual impact can be measured by techniques including, but not limited to, balloon tests and photo simulations.

(d) No lighting of telecommunication facilities is allowed, except as required by the Federal Aviation Administration, Oregon Department of Aviation or other federal or state agencies. Required lighting shall be shielded from the ground to the extent it does not violate state or federal requirements.

(e) Equipment areas shall be enclosed by a chain link fence or equivalent.

(f) Warning and safety signs, up to three square feet in area, are allowed. All other signs are prohibited.

(g) Maintenance and repair of a lawfully existing telecommunication facility does not require a land use application approval.

(h) Changeouts. The changeout of an existing transmission tower or collocation does not require a land use application when the following criteria apply:

(i) The new equipment does not increase the tower height or base diameter.

(ii) No new lights are proposed unless required by the Oregon Department of Aviation (ODA) or the Federal Aviation Administration (FAA).

(iii) The new equipment does not increase the number of antennas or external transmitters. Existing antennas and external transmitters may remain for a period not to exceed six (6) months in order to accommodate the transfer of service from the existing antennas or transmitters to the replacement antennas or transmitters.

(iv) The replacement antennas or external transmitters shall not exceed the size (e.g., area or length) of existing antennas or transmitters by more than twenty (20) percent.

(v) The new equipment shall have a similar exterior color as the existing equipment.

(i) Within a forest zone, the following standards shall apply:

(i) A fuel break shall extend 50 feet surrounding ancillary facilities containing new or replacement propane or gas powered generating equipment. Except for trees, vegetation within the fuel break shall be maintained at less than 24 inches in height. Trees shall be spaced with greater than 15 feet between the crowns and pruned to remove dead and low (less than 8 feet above ground) branches. Nonflammable materials (i.e., gravel) shall be placed within 30 feet surrounding ancillary facilities that contain propane or gas powered generating equipment.

(ii) Private roads and driveways that provide access to new or replacement transmission towers in the forest zones shall comply with the Fire Safety Design Standards of LC 16.211(8)(e)(i) through (vii).

(j) Notice. In lieu of the notice area in LC 14.060(4)(a), when the application involves a leased area notice shall be sent to landowners and applicable community organizations recognized by the Lane County Board of Commissioners in LM 3.513, within ½ mile of the leased area. If the property does not contain a leased area, notice shall be sent as required by LC 14.060(4)(a), as applicable.

(4) Standards for a new or replacement transmission tower.

(a) Review & notice process. An application for placement of a transmission tower requires submittal of an application in accordance with Type III procedures of LC Chapter 14, except that LC 14.060(4)(a) noticing requirements does not apply to applications involving a leased area.. To be approved, the application must comply with LC 16.264(3) and 16.264(4).

(b) Neighborhood meeting. Prior to submittal of a land use application, the applicant shall conduct a neighborhood meeting in the general area of the proposed telecommunication tower.

Lane Code  
CHAPTER 16 CONTENTS

(i) The applicant shall, at least fourteen (14) days but not more than thirty (30) days in advance of the meeting, mail notice of the meeting in conformance with 16.264(3)(j). In addition, the notice shall be sent to tenants living within the noticed area. The notice shall state the date, time, and location of the meeting and that the topic of the meeting is to discuss the proposed location of a telecommunication facility on the subject property and to hear from area residents about any concerns they might have with the proposal. The notice shall state the Lane County map and tax lot numbers for the subject property and the address for the subject property.

(ii) The applicant shall, at least ten (10) days in advance of the meeting, publish notice of the meeting in a newspaper of general circulation serving the area. The published notice shall contain the information required by LC 16.264(4)(b)(i) for the mailed notice.

(iii) Nothing in this subsection limits the applicant from providing additional opportunity for input from area property owners and residents.

(c) Required submittals. The application shall contain the following information:

(i) A site plan, drawn to scale, showing:

(A) Structures. All existing and proposed structures on the site. Include any dwellings or schools within 1200 feet of the tower;

(B) Access. The access road to the site and the public road serving that access road. Submit all necessary easements for access to the site; and

(C) Taxlots. Identify the taxlot containing the telecommunication facility and all taxlots crossed by the access road.

(ii) A description of the tower design and height. The description shall include:

(A) A site-specific study of the tower site identifying the proposed color and surfacing of the tower and ancillary facilities;

(B) The engineered design capacity of the tower in terms of the number and type of collocations it is designed to accommodate;

(C) Documentation in the form of lease agreements for a minimum of two collocations on the proposed telecommunication tower.

(iii) Certification by an Oregon-registered professional engineer that the telecommunication facility, as amended by any proposed collocations, complies with the non-ionizing electromagnetic radiation (NIER) emission standards as set forth by the Federal Communications Commission (FCC).

(iv) A signed statement from the property owner indicating awareness of the removal responsibilities of LC 16.264(4)(f)(iv). A lease agreement or similar authorization for the proposed use from the federal government that includes a removal requirement may be substituted for applications involving telecommunication facilities located on federal land.

(v) Signature(s) of the property owner(s) on the application form or a written statement from the property owner(s) granting authorization to proceed with the land use application. A lease agreement or similar authorization for the proposed use from the federal government may be substituted for applications involving telecommunication facilities located on federal land.

(vi) A map of all transmission towers and properties that have obtained approval for a transmission tower, within ten (10) miles of the proposed facility.

(vii) Certification by an Oregon-registered professional engineer that the design of the tower will support at least three users (the primary user and two collocation sites).

(viii) Evidence of the notification and the neighborhood meeting.

(ix) A performance bond payable to Lane County and acceptable to the Director to cover the cost of removal of the telecommunication tower, ancillary facilities, and restoration of the site.

(x) Other information requested in the application form provided by the Director, such as but not limited to, peer review by an independent engineering firm of the proposed telecommunications facility system design.

(d) Performance standards. The transmission tower shall comply with the following:

Lane Code  
CHAPTER 16 CONTENTS

(i) The tower shall be necessary to provide service to the intended area. The applicant shall provide evidence the existing and approved telecommunication facilities within ten miles would not provide an adequate level of service, based on the following:

- (A) Lack of useable and compatible collocation space;
- (B) Inability to meet service coverage area and capacity needs; or
- (C) Technical reasons such as channel proximity and inter-modulation.

(ii) The transmission tower shall be designed to accommodate at least three users (the primary user and two collocation sites).

(iii) The cumulative radio frequency emissions from all the collocations on a single structure shall not exceed the maximum exposure limits of the FCC.

(iv) When access is provided by a private road, all necessary access easements and roadways shall be maintained.

(v) Prior to land use approval of a building permit for a telecommunication tower, the applicant shall:

(A) Provide documentation showing the FAA, the ODA, and any other applicable state agency, have approved the tower, or that the tower does not require approval by these agencies;

(B) When the tower is within 14,000 feet of an airport, provide the FAA registration number for the transmission tower, or documentation showing the tower does not require registration.

(e) Setbacks and separation requirements.

(i) Setbacks. The tower shall comply with the setback of the base zone.

(ii) Separation. The tower shall be 1200 feet from any dwelling or school, except:

(A) An encroachment into the separation distance is allowed if the homeowner(s) who is being encroached upon submits written approval of the encroachment.

(B) This separation shall not apply to any dwellings or schools located on the parcel containing the proposed tower.

(f) Expiration and Renewal of the Special Use Permit.

(i) If a telecommunications tower is not placed into service within 2 years of issuance of a building permit, the special use permit shall expire.

(ii) In lieu of LC 14.090(6), all conditions of approval must be completed by December 31st of the year following the date of final special use permit approval. No time extensions are allowed. The special use permit shall be renewed every two (2) years thereafter.

(iii) To renew the special use permit, an application shall be submitted in accordance with LC Chapter 14. To be approved, the application shall contain documentation showing:

(A) The telecommunications facility has complied with non-ionizing electromagnetic radiation (NIER) emission standards as set forth by the Federal Communications Commission (FCC); and

(B) The tower continues to meet any applicable conditions of approval by Lane County, including provision of an adequate current performance bond for removal of the facility and restoration of the site.

(iv) If a transmission tower authorized under this section is not used as a telecommunication facility for a period of one (1) year, the special use permit shall expire and the tower shall be removed.

(5) Collocation. A new or replacement collocation shall comply with the following:

(a) Review process. Collocation requires submittal of a land use application pursuant to Type II procedures of LC Chapter 14. Director approval is required pursuant to Type II procedures of LC Chapter 4, excluding the notice area at LC 14.060(4)(a) for applications involving a leased area. To be approved, the application must comply with LC 16.264(3) and 16.264(5).

(b) Required submittals. An application for a collocation shall include the following information:

(i) A site plan, drawn to scale, showing:



Lane Code  
CHAPTER 16 CONTENTS

(A) Structures. All existing and proposed structures on the site. Include any dwellings or schools within 1200 feet of the tower;

(B) Access. The access road to the site and the public road serving that access road. Submit all necessary easements for access to the site; and

(C) Taxlots. Identify the taxlot containing the telecommunication facility and all taxlots crossed by the access road.

(ii) A description of the tower design and height. The description shall include:

(A) A site-specific study of the tower site identifying the proposed color and surfacing of the tower, collocation, and ancillary facilities;

(B) The engineered design capacity of the tower in terms of the number and type of collocations it is designed to accommodate.

(iii) If the collocation is within 14,000 feet of an airport, provide the FAA registration number for the tower structure, or documentation showing that the tower does not require registration.

(iv) Documentation demonstrating that the Oregon Department of Aviation has reviewed the proposal. When the proposed collocation does not increase the height of the tower, documents from the ODA approving the tower may be substituted.

(v) A signed statement from the property owner indicating awareness of the removal responsibilities of LC 16.264(5)(c)(ii). A lease agreement or similar authorization for the proposed use from the federal government that includes a removal requirement may be substituted for applications involving telecommunication facilities located on federal land.

(vi) Signature(s) of the property owner(s) on the application form or a written statement from the property owner(s) granting authorization to proceed with the land use application. A lease agreement or similar authorization for the proposed use from the Federal government may be substituted for applications involving telecommunication facilities located on federal land.

(vii) Certification by an Oregon-registered professional engineer that the telecommunication facility, as amended by the proposed collocation, complies with the non-ionizing electromagnetic radiation (NIER) emission standards as set forth by the Federal Communications Commission (FCC).

(viii) Certification by an Oregon-registered professional engineer that the telecommunication facility will support the proposed collocated equipment.

(ix) Documentation showing that the applicant has an FCC license for the geographic region and for the service proposed by the collocation.

(x) A performance bond payable to Lane County and acceptable to the Director to cover the cost of removal of the collocation, ancillary facilities, and restoration of the site to the way it appeared before collocation approval.

(xi) Other information requested in the application form provided by the Director, such as but not limited to, peer review by an independent engineering firm of the proposed telecommunications facility system design.

(c) Performance standards. Collocations shall comply with the following:

(i) All collocations on the structure shall comply with the non-ionizing electromagnetic radiation (NIER) emission standards as set forth by the Federal Communications Commission (FCC).

(ii) Any collocation and ancillary facilities authorized under this subsection shall be removed after one year of non-use and the approval shall expire.

(iii) The provider shall maintain an FCC license for the geographic region and for the service provided by the collocation.

(6) Spectrum Act Eligible Facilities Requests.

(a) Review Process. An eligible facilities request for a modification of an existing tower or base station that does not substantially change the physical dimensions of such tower or base station will be processed as a Type I determination pursuant to LC Chapter 14 and LC 14.050(2)(c).

Lane Code  
CHAPTER 16 CONTENTS

(b) **Definitions.** Terms in this subsection are defined as provided by 47 C.F.R. 1.40001(b). In the case of conflict between the definitions provided in subsection (2) above and the definitions of 47 C.F.R. 1.40001(b), the definitions of 47 C.F.R. 1.40001(b) prevail.

(c) **Standards.** Type I eligible facilities requests are those that do not constitute a substantial change in the physical dimensions of an existing tower or base station, where substantial change is defined as any of the following:

(i) For towers other than towers in the public rights-of-way, it increases the height of the tower by more than 10% or by the height of one additional antenna array with separation from the nearest existing antenna not to exceed twenty feet, whichever is greater; for other eligible support structures, it increases the height of the structure by more than 10% or more than ten feet, whichever is greater;

(A) Changes in height should be measured from the original support structure in cases where deployments are or will be separated horizontally, such as on buildings' rooftops; in other circumstances, changes in height should be measured from the dimensions of the tower or base station, inclusive of originally approved appurtenances and any modifications that were approved prior to the passage of the Spectrum Act.

(ii) For towers other than towers in the public rights-of-way, it involves adding an appurtenance to the body of the tower that would protrude from the edge of the tower more than twenty feet, or more than the width of the tower structure at the level of the appurtenance, whichever is greater; for other eligible support structures, it involves adding an appurtenance to the body of the structure that would protrude from the edge of the structure by more than six feet;

(iii) For any eligible support structure, it involves installation of more than the standard number of new equipment cabinets for the technology involved, but not to exceed four cabinets; or, for towers in the public rights-of-way and base stations, it involves installation of any new equipment cabinets on the ground if there are no pre-existing ground cabinets associated with the structure, or else involves installation of ground cabinets that are more than 10% larger in height or overall volume than any other ground cabinets associated with the structure;

(iv) It entails any excavation or deployment outside the current site;

(v) It would defeat the concealment elements of the eligible support structure; or

(vi) It does not comply with conditions associated with the siting approval of the construction or modification of the eligible support structure or base station equipment, provided however that this limitation does not apply to any modification that is non-compliant only in a manner that would not exceed the thresholds identified in (6)(c)(i) through (iv).

(d) If the facilities request for modification of an existing tower or base station will substantially change the physical dimensions of such tower or base station, the application will be subject to subsection (5) of this section, a Type II procedure.

*(Revised by Ordinance 4-02, Effective 4.10.02; 17-04, 3.18.05; 6-10, 9.17.10; 20-05, 6.16.20; 20-06, 6.16.20)*

**TRANSPORTATION FACILITIES AND USES RURAL  
COMPREHENSIVE PLAN**

**16.265 Transportation Facilities and Uses.**

(1) **Purpose.** The purpose of this section is to define roadway and other transportation activities, uses, and projects that may be allowed in any land use zone governed by LC Chapter 16, subject to applicable standards and requirements. It clarifies the status of these activities and the processes necessary to implement the Lane County Transportation System Plan (TSP), a Special Purpose Plan of the Rural Comprehensive Plan.

(2) **Definitions.** The definitions in LC 15.010 shall apply to transportation facilities and uses specified in LC 16.265(3) below.

(3) **Transportation Facilities and Uses.** The following transportation facilities and uses may be permitted outright or as special uses only as specified in the applicable land use zone, subject to LC 16.265(4) and other applicable requirements of Lane Code:

(a) Climbing and passing lanes;

Lane Code  
CHAPTER 16 CONTENTS

(b) Reconstruction or modification as defined in LC 15.010, and modernization as defined in LC 15.010 of public roads and highways, including:

(i) acquisition of right-of-way, including the removal or displacement of buildings but not including the creation of new parcels.

(ii) channelization as defined in LC 15.010.

(iii) the placement of utility facilities overhead and in the subsurface of public roads and highways along public right of way.

(iv) the addition of travel lanes.

(v) continuous median turn lanes.

(c) Temporary public road and highway detours that will be abandoned and restored to the condition or use in effect prior to construction of the detour at such time as no longer needed.

(d) Improvement of public roads and related facilities such as maintenance yards, weigh stations and rest areas, to support the operation and maintenance of public roads and highways, including the acquisition of right-of-way but not resulting in the creation of new lots or parcels;

(e) Operations, maintenance, and repair as defined in LC 15.010 of existing transportation facilities, services, and improvements, including road, bicycle, pedestrian, port, airport and rail facilities, and major regional pipelines and terminals.

(f) Preservation as defined in LC 15.010, and rehabilitation activities and projects as defined in LC 15.010 for existing transportation facilities, services, and improvements, including road, bicycle, pedestrian, port, airport and rail facilities, and major regional pipelines and terminals.

(g) Dedication and acquisition of right-of-way, authorization of construction and the construction of facilities and improvements, where the improvements are otherwise allowable and consistent with clear and objective dimensional standards.

(h) Changes in the frequency of transit, rail and airport services.

(i) Park and ride lots.

(j) Realignment as defined in LC 15.010 not otherwise allowed in this section.

(k) Replacement of an intersection with an interchange.

(l) New Roads as defined in LC 15.010 that are County Roads functionally classified as Local Roads or Collectors, or are Public Roads or Local Access Roads as defined in LC 15.010(35) in an exception area, or in other areas where the function of the road is to reduce local access to or local traffic on a state highway. These roads shall be limited to two travel lanes. Private access and intersections shall be limited to rural needs or to provide adequate emergency access.

(m) Transportation facilities, services and improvements other than those listed in LC 16.265(3) that serve local travel needs. The travel capacity and level of service of facilities and improvements serving local travel needs shall be limited to that necessary to support rural land uses identified in the Rural Comprehensive Plan or to provide adequate emergency access.

(n) Bikeways, footpaths and recreation trails not otherwise allowed as a modification or part of an existing road.

(o) Railroad mainlines and branch lines.

(p) Pipelines.

(q) Navigation channels.

(r) Expansion or alterations of public use airports that do not permit service to a larger class of airplanes, as defined by the Federal Aviation Administration.

(4) Modernization projects, and other road improvement projects listed above in LC 16.265(3) that involve the addition of travel lanes, or the displacement or relocation of buildings, shall be subject to the following:

(a) State projects shall be subject to the public involvement policies and actions in the adopted Oregon Transportation Plan, and shall be part of the State Transportation Improvement Program (STIP) adopted by the Oregon Transportation Commission; and

(b) County projects shall be listed in the adopted Capital Improvement Program and approved and processed as to project design pursuant to the citizen involvement requirements in LM 15.580.

*(Revised by Ordinance 10-04, Effective 6.4.04)*

Lane Code  
CHAPTER 16 CONTENTS

*This space intentionally left blank.*

Lane Code  
CHAPTER 16 CONTENTS

**GOSHEN INDUSTRIAL ZONES (GI, LI)  
RURAL COMPREHENSIVE PLAN (RCP)**

**LC 16.280 Goshen Industrial Zones (GI, LI)**

**Sections:**

- (1) Purpose**
- (2) Definitions**
- (3) Land Use Categories**
- (4) Industrial Use Categories**
- (5) Applicability**
- (6) Site Design Review**
- (7) Special Use Permit**
- (8) Permitted Land Uses**
- (9) Development Standards**
- (10) Access and Circulation**
- (11) Landscaping, Fences, Walls and Screening**
- (12) Parking and Loading**
- (13) Noise Standards**
- (14) Outdoor Lighting Standards**
- (15) Signs**
- (16) Utility Facilities**

- (1) Purpose.** The purpose of the Goshen Industrial zones are to promote economic growth and development that takes advantage of the significant comparative advantages of Goshen including presence of rail and highway access, while being in close proximate to the Eugene/Springfield metro area. The zones will accommodate industrial uses focusing on manufacturing and production, industrial service, and accessory or supportive uses to serve the needs of these primary uses. The zones are intended to buffer incompatible industrial developments from other zones, while providing a quality environment for businesses and employees. This Section (16.280) of Lane Code guides the orderly development of Goshen urban industrial uses and is intended to:
  - (a)** Provide for efficient use of land and public services.
  - (b)** Promote the area's transportation and other infrastructure, and logistical advantages.
  - (c)** Encourage economic development, expansion, and creation of jobs in the area.
  - (d)** Increase compatibility between uses and nearby commercial and residential or resource zones.
  - (e)** Provide appropriate design standards to accommodate a range of industrial users.
  - (f)** Utilize industrial zoned lands for increased levels of development resulting in living wage jobs.
  - (g)** Protect and diversify the economy of the county.
  - (h)** Conserve the limited supply of prime industrial lands to provide sufficient space for existing industrial enterprises and future industrial growth.

Two different zones are intended to provide land that is appropriate for the following uses based on size, location, and other characteristics.

**General Industrial (GI):** The purpose of this zone is to provide opportunities for industrial uses that create jobs that pay no less than 150% of the median wage, which are essential to the development of a balanced economic base in an industrial environment with a minimum conflict between industrial uses and non-industrial uses. Additionally, it is the primary purpose of the GI

Lane Code  
CHAPTER 16 CONTENTS

zone to focus on rail dependent uses that create a significant number of jobs. The GI zone is intended to encourage Manufacturing and Production uses which are by their nature expected to create a significant number of jobs.

**Light Industrial (LI):** The purpose of this zone is to provide opportunities for light industrial uses on existing smaller properties.

These zones are identified on the County's official zoning map. The zones serve distinctly different uses as described.

**(2) Definitions**

- (a) Industrial Use** – means employment activities, including, but not limited to the use of land primarily for the manufacture, assembly, fabrication, processing, storage, logistics, warehousing, importation, distribution and transshipment and research and development, that generate income from the production, processing, handling or distribution of goods and services, including goods and services in the traded sector as defined by ORS 285A.010.
- (b) Commercial Use** – means the use of land involving buying or selling of goods or services as the primary activity.
- (c) Corporate Office/Headquarters** – means a building or portion of a building in which people are employed in the management or direction of a business consisting of one or more companies, or divisions or groups of companies. This use must be directly associated with and subordinate to a permitted use or use allowed with a Special Use Permit on the same site.
- (d) Non-native, invasive plants** – means plants listed under current Oregon State University Extension Service Bulletin as non-native invasive plants in Oregon.
- (e) Rail dependent.** A use, facility or activity that demonstrates a benefit from access to rail or can utilize or integrate access to the rail into their business operations.
- (f) Rail related.** Uses or facilities that are not directly dependent upon access to rail, but that provide goods or services that are directly associated with rail-dependent land or use, and that, demonstrate that if not located near rail related uses would result in a loss of quality or increase in cost of the goods or services offered.

**(3) Land Use Categories**

For the purpose of this Chapter uses and activities are classified into use categories on the basis of common functional, product, or physical characteristics, as described below.

- (a) Categorization.** Uses are assigned to the category whose description most closely describes the nature of the primary use. The characteristics subsection of each use category describes the characteristics of each use category. Developments may have more than one primary use. Developments may also have one or more accessory uses.
- (b) Interpretation.** When a use's category is not clearly identifiable, the Director, through an administrative action, determines the applicable use category. The following is considered

Lane Code  
CHAPTER 16 CONTENTS

to determine what use category the use is in, and whether the activities constitute primary uses or accessory uses:

- (i) The description of the activity(ies) in relationship to the characteristics of each use category;
- (ii) The relative amount of site or floor space and equipment devoted to the activity;
- (iii) Relative amounts of sales from each activity;
- (iv) The customer type for each activity;
- (v) The relative number of employees in each activity;
- (vi) Hours of operation;
- (vii) Building and site arrangement;
- (viii) Vehicles used with the activity;
- (ix) The relative number of vehicle trips generated by the activity;
- (x) Signs;
- (xi) How the use advertises itself; and
- (xii) Whether the activity would function independently of the other activities on the site.

- (c) **Developments with multiple primary uses.** When all of the primary uses of a development fall within one use category, then the development is assigned to that use category. For example, a development that contains a Research and Development facility and a manufacturing and production facility, the uses would be classified in the Industrial category because all the primary uses are in that category. When the primary uses of a development fall within different use categories, each primary use is classified in the applicable category and is subject to the regulations for that category.

**(4) Industrial Use Categories**

**(a) Industrial Service**

- (i) “Industrial Service” refers to the repair or servicing of industrial, business or consumer machinery, equipment, products or by-products. Firms that service consumer goods do so by mainly providing centralized services for separate retail outlets. Contractors and building maintenance services and similar uses perform services off-site. Few customers, especially the general public, come to the site.
- (ii) Accessory uses may include but are not limited to offices, parking, storage, rail spur or lead lines, and docks.
- (iii) Examples include welding shops; machine shops; tool repair; electric motor repair; repair of scientific or professional instruments; storage, salvage or wrecking of heavy machinery, metal, and building materials; towing and vehicle storage; auto and truck salvage and wrecking; heavy truck servicing and repair; tire re-treading or recapping; truck stops; building, heating, plumbing or electrical contractors; printing, publishing and lithography; exterminators; recycling operations; janitorial and building maintenance services; fuel oil distributors; solid fuel yards; research and development laboratories; technology development and support centers; industrial laundry, dry-cleaning, and carpet cleaning plants; and photofinishing laboratories.
- (iv) Exceptions

Lane Code  
CHAPTER 16 CONTENTS

- (aa) Contractors and others who perform Industrial Services off-site are included in the office category, if equipment and materials are not stored at the site, and fabrication or similar work is not carried on at the site.
- (bb) Hotels, restaurants, and other services that are part of a truck stop are considered accessory to the truck stop.

**(b) Manufacturing and Production**

- (i) “Manufacturing and Production” refers to the manufacturing, processing, fabrication, packaging, or assembly of goods. Natural, human-made, raw, secondary, or partially completed materials may be used. Products may be finished or semi-finished and are generally made for the wholesale market, for transfer to other plants, or to order for firms or consumers. Goods are generally not displayed or sold on site, but if so, they are a subordinate part of sales. Relatively few customers come to the manufacturing site.
- (ii) Accessory uses may include but are not limited to offices, cafeterias, parking, employee recreational facilities, warehouses, storage yards, rail spur or lead lines, docks, repair facilities, or truck fleets. Living quarters for one caretaker per site is allowed. Other living quarters are subject to the regulations for Residential Uses.
- (iii) Examples include processing of food and related products; catering establishments; breweries, distilleries, and wineries; weaving or production of textiles or apparel; lumber mills, pulp and paper mills, and other wood products manufacturing; woodworking, including cabinet makers; production of chemical, rubber, leather, clay, bone, plastic, stone, or glass materials or products; movie production facilities; concrete batching and asphalt mixing; production or fabrication of metals or metal products including enameling and galvanizing; manufacture or assembly of machinery, equipment, instruments, computer and electronic devices; biotechnology; production of artwork and toys; sign making; production of prefabricated structures, including manufactured homes; the production of energy; and paper products processing.
- (iv) Exceptions
  - (aa) Manufacturing of goods to be sold primarily on-site and to the general public is classified as Retail Sales and Service.
  - (bb) Manufacture and production of goods from composting organic material is classified as Waste-Related uses.

**(c) Warehouse, Freight Movement, and Distribution**

- (i) “Warehouse, Freight Movement, and Distribution” refers to the storage, or movement of goods by a company for themselves or other firms. Goods are generally delivered to other firms or the final consumer, except for some will-call pickups. There is little on-site sales activity with the customer present.
- (ii) Accessory uses may include but are not limited to offices, truck fleet parking and maintenance areas, rail spur or lead lines, docks, and repackaging of goods.



Lane Code  
CHAPTER 16 CONTENTS

- (iii) Examples include separate warehouses used by retail stores such as furniture and appliance stores; household moving and general freight storage; cold storage plants, including frozen food lockers; major wholesale distribution centers; truck/freight terminals; bus barns; parcel services; major post offices; grain terminals; and the stockpiling of sand, gravel, or other aggregate materials.
- (iv) Exceptions
  - (aa) Uses that involve the transfer or storage of solid or liquid wastes are classified as Waste-Related uses.
  - (bb) Mini-warehouses are classified as Self-Service Storage uses.
- (d) **Waste-Related**
  - (i) “Waste-Related” refers to uses that receive solid or liquid wastes from others for disposal on the site or for transfer to another location, uses that collect sanitary wastes, or uses that manufacture or produce goods or energy from the biological decomposition of organic material. Waste-Related uses also include uses that receive hazardous wastes from others and are subject to the regulations of OAR 340-100-110, Hazardous Waste Management.
  - (ii) Accessory uses may include but are not limited to recycling of materials, offices, and repackaging and transshipment of by-products.
  - (iii) Examples include sanitary landfills, limited use landfills, waste composting, energy recovery plants, sewer treatment plants, portable sanitary collection equipment storage and pumping, and hazardous-waste-collection sites.
  - (iv) Exceptions
    - (aa) Disposal of clean fill, as defined in OAR 340-093-0030, is considered a fill, not a Waste-Related use.
    - (bb) Sewer pipes that serve a development are considered a basic utility.
    - (cc) Recycling operations are not considered a Waste related use. They are classified as an Industrial Service use.
- (e) **Wholesale Sales**
  - (i) “Wholesale Sales” refers to the sale, lease, or rent of products primarily intended for industrial, institutional, or commercial businesses. The uses emphasize on-site sales or order taking and often include display areas. Businesses may or may not be open to the general public, but sales to the general public are limited as a result of the way in which the firm operates. Products may be picked up on site or delivered to the customer.
  - (ii) Accessory uses may include but are not limited to offices, product repair, warehouses, parking, minor fabrication services, and repackaging of goods.

Lane Code  
CHAPTER 16 CONTENTS

- (iii) Examples include sale or rental of machinery, equipment, heavy trucks, building materials, special trade tools, welding supplies, machine parts, electrical supplies, janitorial supplies, restaurant equipment, and store fixtures; mail order houses; and wholesalers of food, clothing, auto parts, building hardware, and office supplies.
- (iv) Exceptions
  - (aa) Firms that engage primarily in sales to the general public are classified as Retail Sales and Service.
  - (bb) Firms that engage in sales on a membership basis are classified as Retail Sales and Service.
  - (cc) Firms that are primarily storing goods with little on-site business activity are classified as Warehouse, Freight Movement, and Distribution.

**(5) Applicability**

The provisions of this subsection of Lane Code Chapter 16, the Goshen Industrial zones, apply to all development on property zoned General Industrial (GI) and Light Industrial (LI) within the unincorporated community of Goshen. The location of the GI and LI zones are identified on the Lane County official zoning map.

Where a provision or condition imposed by a provision of this section conflicts or overlaps with another provision or condition imposed by a provision of this section or other section of Chapter 16 of Lane Code, the provision or condition imposed by a provision that is more restrictive governs.

**(6) Site Design Review**

- (a) **Purpose.** The purpose of this subsection, Site Design Review, is to:
  - (i) Provide rules, regulations and standards for efficient and effective administration of land use review in the Goshen Industrial Zones;
  - (ii) Promote the public health, safety and general welfare;
  - (iii) Provide compatibility through provisions for adequate light and air, prevent overcrowding of land, and provide for adequate transportation, water supply, sewage, fire protection, pollution control, surface water management, and protection against natural hazards;
  - (iv) Encourage the conservation of energy resources; and
  - (v) Encourage efficient use of land resources, full utilization of services, mixed uses, and transportation options.
- (b) **Applicability.** Site Design Review is required for all new developments and modifications of existing developments in the Goshen Industrial zones, subject to this section of Lane Code Chapter 16, in accordance with subsection (5), Applicability, of this section. Regular maintenance, repair and replacement of materials (e.g., roof, siding,

Lane Code  
CHAPTER 16 CONTENTS

awnings, etc.), parking resurfacing and similar maintenance and repair are exempt from Site Design Review.

- (c) **Application Review.** Site Design Review will be processed pursuant to Type II procedures of LC Chapter 14, and subject to the application requirements and approval criteria contained in subsections 6(e) and 6(f), below.

Site Design Review ensures compliance with the basic land use and development standards of the land use zone, such as setbacks, lot coverage, building height, property size, orientation, architectural standards and other provisions of Lane Code as applicable.

- (d) **Permit Approval and Modifications.** Applicant must not commence or authorize development until the applicant has received all of the appropriate land use and development approvals (i.e., site design review approval, and any other required land use decisions) and building permits. Applicant must not commence or authorize construction of public improvements until the County has approved all required public improvement plans (e.g., utilities, streets, public land dedication, etc.). The County may require the applicant to enter into a development agreement (e.g., for phased developments and developments with required off-site public improvements), and may require bonding or other assurances for improvements.

Modification of application for a Site Design Review or Special Use Permit application means the applicant's submittal of new information after an application has been deemed complete and prior to the close of the record on a pending application that would modify a development proposal by changing one or more of the following components: proposed uses, operating characteristics, intensity, scale, site lay out (including but not limited to changes in setbacks, access points, building design, size or orientation, parking, traffic or pedestrian circulation plans), or landscaping in a manner that requires the application of new criteria to the proposal or that would require the findings of fact to be changed. It does not mean an applicant's submission of new evidence that merely clarifies or supports the pending application.

- (i) An applicant may modify an application at any time during the approval process up until the issuance of an administrative decision, or the close of the record for an application reviewed under a hearings process.
- (ii) The Approval Authority may not consider any evidence submitted by or on behalf of an applicant that would constitute modification of an application unless the applicant submits an application for a modification, pays all required modification fees and agrees in writing to restart the 150-day review period as of the date the modification is submitted. The 150-day review period for an application, as modified, may be restarted as many times as there are modifications up to a total of 365 days from the day the application was accepted as complete.
- (iii) The Approval Authority may require that the application be re-noticed and additional hearings be held.
- (iv) Up until the day a hearing is opened for receipt of oral testimony, the Director has sole authority to determine whether an applicant's submittal constitutes a modification. After such time, the Approval Authority makes such determinations. The Approval Authority's determination on whether a submittal

Lane Code  
CHAPTER 16 CONTENTS

constitutes a modification is appealable to LUBA after a final decision is entered by the County on an application.

- (e) **Site Design Review - Application Submittal Requirements.** All of the following information is required for Site Design Review application submittal:
- (i) **Site Design Review Submission Requirements.** An application for Site Design Review must contain all of the information required under LC 14.040(1). In addition an applicant for Site Design Review must provide the following additional information, as deemed applicable by the Director. The Director may deem applicable any information that he or she needs to review the request and prepare a complete staff report and recommendation to the Approval Authority:
- (aa) **Site analysis map.** (existing conditions) At a minimum the site analysis map must contain the following:
- (A) The applicant's entire property and the surrounding property to a distance sufficient to determine the location of the development in the County (minimum of 250 feet), and the relationship between the proposed development site and abutting property and development. The property boundaries, dimensions and gross area must be identified;
  - (B) Topographic contour lines at 2-foot intervals for slopes of less than 10 percent, and 5-foot intervals for steeper slopes;
  - (C) Identification of slopes greater than 25 percent;
  - (D) The location and width of all existing: utilities, public and private streets, drives, sidewalks, pathways, rights-of-way, and easements on the site and adjoining the site;
  - (E) Potential natural hazard areas, including any areas identified as subject to a 100-year flood, areas subject to high water table, and areas mapped by the County or State as having a potential for geologic hazards;
  - (F) Resource areas, including marsh and wetland areas, streams, and wildlife habitat identified by the County or any natural resource regulatory agencies as requiring protection;
  - (G) Site features, including existing structures, pavement, large rock outcroppings, drainage ways, canals and ditches;
  - (H) Locally or federally designated historic and cultural resources on the site and abutting parcels or lots;
  - (I) The location, size and species of trees and other vegetation having a caliper (diameter) of six (6) inches or greater at four feet above grade;

Lane Code  
CHAPTER 16 CONTENTS

- (J) North arrow, scale, names and addresses of all persons listed as owners of the subject property on the most recently recorded deed;
  - (K) Name and address of project designer, engineer, surveyor, and/or planner, if applicable.
- (bb) **Proposed site plan.** The site plan must contain the following information:
- (A) The proposed development site, including boundaries, dimensions, and gross area;
  - (B) Features identified on the existing site analysis maps that are proposed to remain on the site;
  - (C) Features identified on the site analysis map, if any, which are proposed to be removed or modified by the development;
  - (D) The location and dimensions of all proposed public and private streets, drives, rights-of-way, and easements;
  - (E) The location and dimensions of all existing and proposed structures, utilities, pavement and other improvements on the site including outdoor storage areas, fencing, etc. All impervious and pervious areas must be delineated. Setback dimensions for all existing and proposed buildings must be provided on the site plan;
  - (F) The location and dimensions of entrances and exits to the site for vehicular, pedestrian, and bicycle access;
  - (G) The location and dimensions of all parking and vehicle circulation areas (show striping for parking stalls and wheel stops);
  - (H) Pedestrian and bicycle circulation areas, including sidewalks, internal pathways, pathway connections to abutting properties, and any bicycle lanes or trails;
  - (I) Loading and service areas for waste disposal, loading and delivery;
  - (J) Outdoor recreation spaces, common areas, plazas, outdoor seating, street furniture, and similar improvements;
  - (K) Location, type, and height of outdoor lighting;
  - (L) Location of mail boxes, if known;
  - (M) Name and address of project designer, if applicable;

Lane Code  
CHAPTER 16 CONTENTS

- (N) Locations of bus stops and other public or private transportation facilities;
- (O) Locations, sizes, and types of signs;
- (cc) **Architectural drawings.** Architectural drawings demonstrating compliance with subsection (9)(e), Design Standards, below, and showing one or all of the following are required for new buildings and major remodels:
  - (A) Building elevations (as determined by the County Director) with building height and width dimensions;
  - (B) Building materials, colors and type;
  - (C) The name of the architect or designer.
- (dd) **Preliminary grading plan.** A preliminary grading plan prepared by a registered engineer is required for development sites ½ acre or larger. The preliminary grading plan must show the location and extent to which grading will take place, indicating general changes to contour lines, slope ratios, slope stabilization proposals, and location and height of retaining walls, if proposed. Surface water detention and treatment plans may also be required, in accordance with subsection (16)(d), Stormwater Management Requirements.
- (ee) **Landscape plan.** A landscape plan is required demonstrating compliance with the provisions of subsection (11), Landscaping, Fences, Walls and Screening, below, and must show the following:
  - (A) The location and height of existing and proposed fences, buffering or screening materials;
  - (B) The location of existing and proposed terraces, retaining walls, decks, patios, shelters, and play areas;
  - (C) The location, size, and species of the existing and proposed plant materials (at time of planting);
  - (D) Existing and proposed building and pavement outlines;
  - (E) Specifications for soil at time of planting, irrigation if plantings are not drought-tolerant (may be automatic or other approved method of irrigation) and anticipated planting schedule;
  - (F) Other information as deemed appropriate by the County Director.
- (ff) Sign drawings must detail the location, size, and colors of any proposed signs.

Lane Code  
CHAPTER 16 CONTENTS

- (gg) Deed restrictions. Copies of all existing and proposed restrictions or covenants, including those for access control.
  - (hh) Narrative. Letter or narrative report documenting compliance with the applicable approval criteria contained in subsection (6)(f), Site Design Review Approval Criteria.
  - (ii) Traffic Impact Study, when required in accordance with subsection (16)(b), Roads, below, a traffic study must be prepared in accordance with the road authority's requirements. See Lane Code 15.696-15.697 for relevant standards.
  - (jj) Other information. When determined by the Director, the County may require studies or exhibits prepared by qualified professionals to address specific site features or project impacts (e.g., traffic, noise, environmental features, natural hazards, etc.), in conformance with this Code including but not limited to:
    - (A) **Public Facilities and Services Impact Study.** An impact study when required must quantify and assess the effect of the development on public facilities and services. The scope of the study will be determined by the County during the pre-application conference. For each public facility system and type of impact, the study must propose improvements necessary to meet County standards;
    - (B) In situations where this Code authorizes the dedication of real property to the County, in order for the County to include the dedication as a condition of approval the County must include in the written decision evidence that shows that the required property dedication is directly related to and roughly proportional to the projected impacts of the development on public facilities and services.
- (f) **Site Design Review Approval Criteria.** The Approval Authority must make written findings with respect to all of the following criteria when approving, approving with conditions, or denying an application:
- (i) The application is complete, as determined in accordance with LC 14.050 and subsection (6)(e), Site Design Review – Application Submittal Requirements, above.
  - (ii) The application complies with all of the applicable provisions of the underlying Land Use Zone, including: setbacks, lot coverage, building height, property size, orientation, architectural standards and other provisions of subsections (8), Permitted Land Uses, and (9), Development Standards including special standards as may be required for certain land uses.
  - (iii) The applicant is required to upgrade any existing development that does not comply with the applicable land use zone standards, in conformance with section (5) and Lane Code Chapter 16.251, Non-Conforming Uses.

Lane Code  
CHAPTER 16 CONTENTS

- (iv) The application complies with all of the following Standards as applicable:
  - (aa) subsection (10) - Access and Circulation;
  - (bb) subsection (11) - Landscaping, Fences, Walls and Screening;
  - (cc) subsection (12) - Parking and Loading;
  - (dd) subsection (13) – Noise Standards;
  - (ee) subsection (14) – Outdoor Lighting Standards;
  - (ff) subsection (15) – Signs;
  - (gg) subsection (16) – Utility Facilities.
- (g) Existing conditions of approval required as part of a prior Land Division, Special Use Permit, Site Plan/Design approval or other approval must be met when the development under the previous approval is proposed to continue to exist.

**(7) Special Use Permit**

The County must approve, approve with conditions, or deny an application for a Special Use Permit or to enlarge or alter a Special Use based on findings with respect to each of the following standards and criteria:

- (a) **Use Criteria**
  - (i) The site size, dimensions, location, topography and access are adequate for the needs of the proposed use, considering the building mass, parking, traffic, noise, vibration, exhaust/emissions, light, glare, erosion, odor, dust, visibility, safety, and aesthetic considerations.
  - (ii) Any negative impacts of the proposed use on adjacent properties and on the public can be mitigated through application of other Code standards, or other reasonable conditions of approval that include but are not limited to those listed in below.
- (b) **Site Design Standards.** Where appropriate, the procedures, submittal requirements, and approval criteria for Site Design Review approval listed in subsection (6); Site Design Review must be met.
- (c) **Conditions of Approval.** The County may impose conditions that are found necessary to ensure that the use is compatible with other uses in the vicinity, and that any negative impact of the proposed use on the surrounding uses and public facilities is minimized. The County may impose as many of these and other applicable conditions on one conditional use application as it finds necessary. These conditions include, but are not limited to, the following:
  - (i) Limiting the hours, days, place and/or manner of operation;



Lane Code  
CHAPTER 16 CONTENTS

- (ii) Requiring site or architectural design features that minimize environmental impacts such as noise, vibration, exhaust/emissions, light, glare, erosion, odor and/or dust;
- (iii) Requiring larger setback areas, lot area, and/or lot depth or width than those required;
- (iv) Limiting the building height, size or lot coverage, and/or location on the site;
- (v) Designating the size, number, location and/or design of vehicle access points or parking areas;
- (vi) Requiring street right-of-way to be dedicated and street(s), sidewalks, curbs, planting strips, pathways, or trails to be improved, so long as findings in the development approval indicate how the dedication and/or improvements, if not voluntarily accepted by the applicant, is roughly proportional and has a nexus to the impact of the proposed development;
- (vii) Requiring landscaping, screening, stormwater management facilities, and/or improvement of parking and loading areas;
- (viii) Limiting the number, size, location, height and/or lighting of signs;
- (ix) Limiting or setting standards for the location, design, and/or intensity of outdoor lighting;
- (x) Requiring berms, screening or landscaping and the establishment of standards for their installation and maintenance;
- (xi) Requiring and designating the size, height, location and/or materials for fences;
- (xii) Requiring the protection and preservation of existing trees, soils, vegetation, watercourses, habitat areas, drainage areas, historic resources, cultural resources, and/or sensitive lands;
- (xiii) Requiring the dedication of sufficient land to the public, and/or construction of a pedestrian/bicycle pathways in accordance with adopted plans, so long as findings in the development approval indicate how the dedication and/or construction, if not voluntarily accepted by the applicant, is roughly proportional to the impact of the proposed development. Dedication of land and design and construction must conform to the provisions of this Chapter.

**(8) Permitted Land Uses**

- (a) **Permitted Uses.** The land uses listed in Table 8-1 may be permitted in each of the applicable zoning zones as listed in Table 8-1, subject to the provisions of this section. Only land uses that are specifically listed in Table 8-1, and land uses that are approved as “similar” to those in Table 8-1, may be permitted.

Lane Code  
CHAPTER 16 CONTENTS

- (b) **Determination of Similar Land Use.** Subject to prior submittal and approval of an application pursuant to Type II procedures of LC Chapter 14, uses and development similar to uses and development in Table 8-1 may be allowed if found by the Director to be “clearly similar” to the uses and development allowed by Table 8-1. The applicant has the burden to provide sufficient information to allow the Director to make findings on the following criteria. The Director must make findings that such use is “clearly similar” based on the following criteria:
- (i) The use and development are consistent with the purpose of this section.
  - (ii) When compared with the uses and development permitted by Table 8-1, the use and development are similar to one or more of these uses and development based on an analysis of the:
    - (aa) Goods or services traded from the site;
    - (bb) Bulk, size, and operating characteristics of the proposed use and development;
    - (cc) Parking demand, customer types and traffic generation; and
    - (dd) Intensity of land use and the number of jobs created on the site. Uses proposed in the GI zone must create a job density of 13 jobs per net developed acre.
  - (iii) The use and development do not exceed the carrying capacity of the soil or of existing water supply resources and sewer services. Factual information must be provided about any existing or proposed sewer or water systems for the site and the site's ability to provide onsite sewage disposal and water supply if a community sewer or water system is not available.
  - (iv) The use and development do not result in public health hazards or adverse environmental impacts that violate state or federal regulations.
  - (v) The use and development comply with the other applicable provisions of this Chapter.

Similar use determinations that are not “clearly similar” because they do not meet the standards above, must be made in conformance with the procedures in Lane Code Chapter 16.008; Interpretations. Uses proposed in the GI zone must create a job density of 13 jobs per net developed acre.

- (c) **Existing Uses.** Existing lawfully established uses within an industrial zone located within the Unincorporated Community of Goshen prior to the date of adoption of the ordinance implementing this Chapter constitute permitted uses. Expansion or enlargement of the above pre-existing lawfully established uses or structures are subject to the provisions of Lane Code 16.292 and other sections as applicable.

Lane Code  
CHAPTER 16 CONTENTS

**Table 8-1: Permitted Land Uses**

Land Use	GI	LI
<b>Industrial</b>		
Manufacturing and production	-	-
Rendering plant/facility	N	N
Slaughter house/facility	N	N
Uses with a total building size of not more than 40,000 square feet	P	P
Rail dependent use over 40,000 square feet	P	P
Rail related use over 40,000 square feet on sites without rail access	P	P
Non-rail dependent or non-rail related use over 40,000 square feet	N	P
Industrial Service	S*	P
Towing, vehicle storage, auto and truck salvage and wrecking	N	S
Truck stops	N	S
Warehouse , Freight Movement, and Distribution	S*	S
Waste-Related uses	N	N
Wholesale sales	N	N
<b>Residential</b>		
One caretaker unit is permitted for each development <i>NOTE: Other residential uses are not permitted, however, residences existing prior to the effective date of this Code may continue subject to the standards in Chapter 16.251 Non-Conforming Uses and Developments.</i>	P	P
<b>Commercial</b>		
Commercial/retail uses – existing properties with past commercial uses	N	P*
Vehicle, equipment and boat repair, rental, storage, service	N	N
Medical and dental laboratories and large animal veterinary clinics	N	N
Outdoor Commercial Uses ( <i>e.g.</i> , outdoor storage, Building and garden supply)	N	N
Small-scale personal and professional services ( <i>e.g.</i> , child care, fitness center, coffee shop / deli, dry cleaners, barber shops and salons, copy center, banks, and financial institutions and similar uses) up to 2500 square feet or 1% of gross floor area (whichever is greater)	P*	P*
Equipment Rental and Repair services	N	S
Corporate Office/Headquarters	P*	P*
Mini-storage Warehouse	N	N
Contractor business	N	P
Heavy equipment sales	N	S
Ambulance Service/Transportation yards	N	N
Commercial parking lot	N	N
Recreation Facility (privately owned)	N	N
<b>Public and Institutional</b>		
Government facilities where the public is generally not received. ( <i>e.g.</i> , public safety, utilities, school district bus facilities, public works yards, transit and transportation, and similar facilities)	N	S
Utilities (above ground)	P*	P*
Special district and Public Safety facilities ( <i>e.g.</i> , utility district, fire station, and similar facilities)	S	S
Vocational schools	N	S
Public Park and Recreation Facility	N	S
<b>Miscellaneous Uses</b>		
Wireless and Broadcast Communication Facilities (See LC 16.264)	P	P

**Key to Zones:**

GI = General Industrial Zone

LI = Light Industrial Zone

**Key to Permitted Uses**

P = Permitted; subject to subsection (6).

N = Not Permitted.

S = Special Use Permit required, subject to subsection (7).

Lane Code  
CHAPTER 16 CONTENTS

\* = Subject to Standards for Certain Uses (subsection (9)(g))

Lane Code  
CHAPTER 16 CONTENTS

**(9) Development Standards**

**(a) Setbacks.** Development setbacks provide separation between industrial and non-industrial uses for fire protection/security, building maintenance, sunlight and air circulation, noise buffering, and visual separation. All developments must meet applicable fire and building code standards, which may require greater setbacks than those listed in the following subsection. (e.g., for combustible materials, etc.)

**(i) Front Yard Setbacks.**

- (aa)** General Industrial (GI) Zone: The minimum front yard setback is 20 feet.
- (bb)** Light Industrial (LI) Zone: The minimum front yard setback is 10 feet.
- (cc)** Exceptions:

**(A)** Other special setbacks in conformance with Lane Code 15.065-15.095, Building Setback Requirements may apply.

**(ii) Rear Yard Setbacks.** There is no required rear yard setback in the GI or LI industrial zones, except when development is abutting a residential or resource zone. In this situation, no building or structure or any portion of the use may be constructed or placed closer than 20 feet from the property line of the residential or resource zone. Portions of buildings or structures that exceed 35 feet in height must step back an additional ½ foot for each foot by which the building height exceeds 35 feet.

**(iii) Side Yard Setbacks.** There are no required side-yard setbacks in the GI or LI industrial zones, except when development is abutting a residential or resource zone. In this situation, no building or structure or any portion thereof may be constructed closer than 20 feet to the residential or resource zone. Portions of buildings or structures that exceed 35 feet in height must step back an additional ½ foot for each foot by which the building height exceeds 35 feet.

**Table 9-1: Development Standards**

Standard	Light Industrial (LI)	General Industrial (GI)
Minimum Front Yard	10'	20'
Minimum Rear Yard*	0'/20'*	0'/20'*
Minimum Side Yard*	0'/20'*	0'/20'*
Maximum Lot Coverage	80%	80%
Base Building Height**	65'	65'
Property size (lot, parcel, or unit of land)	Minimum N/A Maximum N/A	Minimum 35 acres Maximum N/A

Note: Setbacks are measured from the minimum right of way widths established in Lane Code Chapter 15.

\*Subject to the provisions of subsection 9(a); Setbacks

\*\*Subject to the provisions of subsection 9(c); Building Height

**(iv) Corner Lots and Through Lots.** For buildings on properties with more than one street frontage or through lots, the minimum front yard setback standards in Table 9-1 applies to all street frontages.

Lane Code  
CHAPTER 16 CONTENTS

- (b) **Lot Coverage.** The lot coverage standards are intended to provide flexibility in development while ensuring some provision of open space for landscaping and stormwater management.

The maximum allowed lot coverage in the General Industrial (GI) and Light Industrial (LI) zones is 60 percent (60%). The maximum allowed lot coverage is computed by calculating the total area covered by buildings including accessory structures, and comparing this figure with the total area of the development site. Compliance with other sections of this code may preclude development of the maximum lot coverage for some land uses.

- (c) **Building Height.** The following building height standards are intended to promote land use compatibility and flexibility for industrial development at an appropriate community scale:

(i) **Height Requirements**

**Base Height.** The base height for buildings and structures in the General Industrial (GI) and Light Industrial (LI) zones is sixty five feet (65') in height and must comply with the building setback standards in subsection 9(a); Setbacks above.

The height limits are subject to the provisions of Lane Code (LC) 16.250(5)(a) and (b).

(ii) **Exceptions**

The allowable height may be increased over the base height when:

- (aa) For a use located on a property or in a building that is within 100 feet of a residential or resource zone, the height may be increased over the base height through one of the following means:

- (A) The minimum required setbacks are increased ½ foot for every foot over the base height;
- (B) Stepping-back of building height ½ foot for every foot over the base height;

and when a Special Use Permit is approved subject to the Special Use Permit criteria and when one or more of the mitigation methods specified below under (iii) are applied.

- (bb) For a use located on a property that is not within 100 feet of a residential or resource zone, the height may be increased over the base height through one on the following means:

- (A) The minimum required setbacks are increased ½ foot for every foot over the base height;
- (B) Stepping-back of building height ½ foot for every foot over the base height;

and when one or more of the following mitigation methods are applied.

Lane Code  
CHAPTER 16 CONTENTS

**(iii) Mitigation Methods.**

- (aa)** visual buffering or screening is provided to mitigate the additional height from surrounding properties; and/or
- (bb)** other appropriate measures to provide a height transition between industrial development and abutting residential or resource zoned property.

Non-conforming uses that are lawfully in existence at the time this ordinance is adopted may continue to operate in conformance with Lane Code 16.251 Non-Conforming Uses.

- (d) Property Size.** One of the necessary components to provide an adequate supply of large economic development land is to ensure that there are large property sizes available for employment uses. The minimum property size limit for properties (lots, parcels, or units of land) within the GI zone are regulated to ensure efficient utilization of the existing industrial zoned land within the community of Goshen.

**Table 9-2: Property Size**

Standard	Light Industrial (LI)	General Industrial (GI)
Property size (lot, parcel, or unit of land)	Minimum N/A Maximum N/A	Minimum 35 acres Maximum N/A

- (e) Land Division Standards.** Land divisions of GI zoned properties that have rail access must preserve rail access for all newly created lots or parcels.

**(f) Design Standards.**

- (i) Orientation.** In order to minimize adverse impacts of parking, traffic, noise, vibration, exhaust/emissions, light, glare, erosion, odor, dust, visibility, safety, and aesthetic considerations to and protect the privacy of abutting non-industrial zoned properties the following standards apply to all development in the Industrial zones when abutting to a non-industrial zone.

- (aa) Openings.** No openings other than code required egress intended for emergency use, are allowed on any side of a building facing the non-industrial use unless approved through a Special Use permit;
- (bb) Front Entrance.** The front/main entrance of the primary building on a property must be oriented to the street frontage and away from any abutting non-industrial zone unless approved through a Special Use Permit;
- (cc) Equipment Standard.** Mechanical equipment, outdoor storage and outdoor manufacturing, and service and delivery areas of an Industrial Use that are outside of an enclosed building, must be located a minimum of 20 feet away from abutting residential or resource zones, schools, and parks, unless approved through a Special Use Permit;

Lane Code  
CHAPTER 16 CONTENTS

Mechanical equipment, outdoor storage, outdoor manufacturing, and service and delivery areas of an Industrial Use that are outside of an enclosed building must be screened from view from all abutting public streets and abutting residential or resource zoned properties, schools, and parks, unless approved through a Special Use Permit. When screening is required, such screening must be a minimum of 6 feet in height and provided by:

- (A) a decorative sight obscuring wall (i.e., wood, masonry or similar quality material),
- (B) evergreen hedge,
- (C) opaque/sight obscuring fence complying with subsection (11), or
- (D) a similar feature that provides an opaque/sight obscuring barrier.

Walls, fences, and hedges must comply with subsection (11), Landscaping, Fences, Walls and Screening; the vision clearance requirements of Lane Code (LC) 15.095(3) and as defined in LC 15.010(40); and provide for pedestrian circulation, in accordance with subsection (10), Access and Circulation.

**Figure 9-1 - Development Orientation**

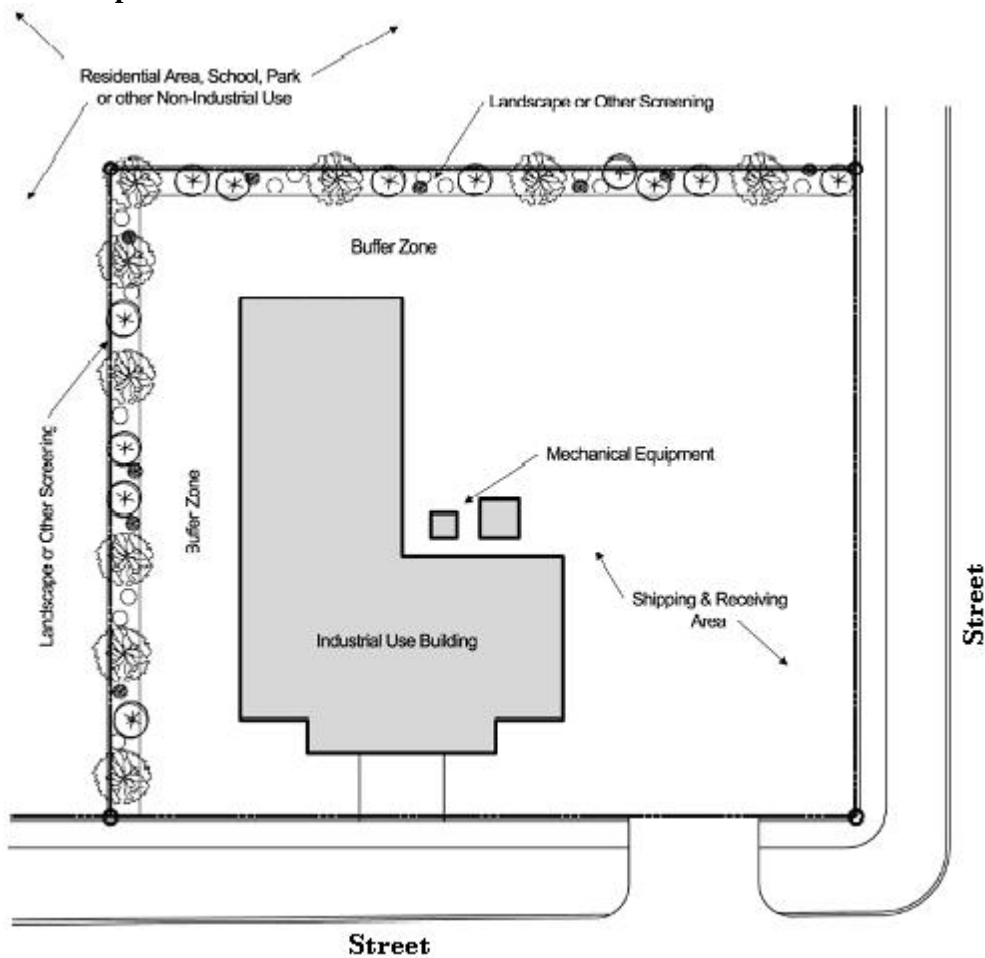

- (ii) **Architectural Standards.** All developments in the Industrial Zones must be evaluated during Site Design Review for conformance with the criteria below:



Lane Code  
CHAPTER 16 CONTENTS

- (aa) **Building Mass.** Where building elevations are oriented to the street, architectural features such as windows, pedestrian entrances, building offsets, projections, detailing, change in materials or similar features, must be used to break up and articulate large building surfaces and volumes greater than 75 linear feet in length. A minimum of 15% of the horizontal building façade must contain a variety of architectural features. The horizontal building elevation facing Highway 99 or Hampton Road in all development within the Industrial Zone with lots fronting on Highway 99 or Hampton Road must provide a minimum of 30% of the architectural features as described above.

Buildings over 10,000 square feet in size must incorporate changes in building direction (i.e., articulation) and divide large masses into varying heights and sizes. Such changes may include building offsets; projections; changes in elevation or horizontal direction; sheltering roofs; terraces; a distinct pattern of divisions in surface materials; windows, and screening trees. The maximum width or length of a building may not exceed 80 feet (from end-wall to end-wall), except that this standard may be increased through the approval of a Special Use Permit.

**Figure 9-2 - Architectural Features (Typical)**

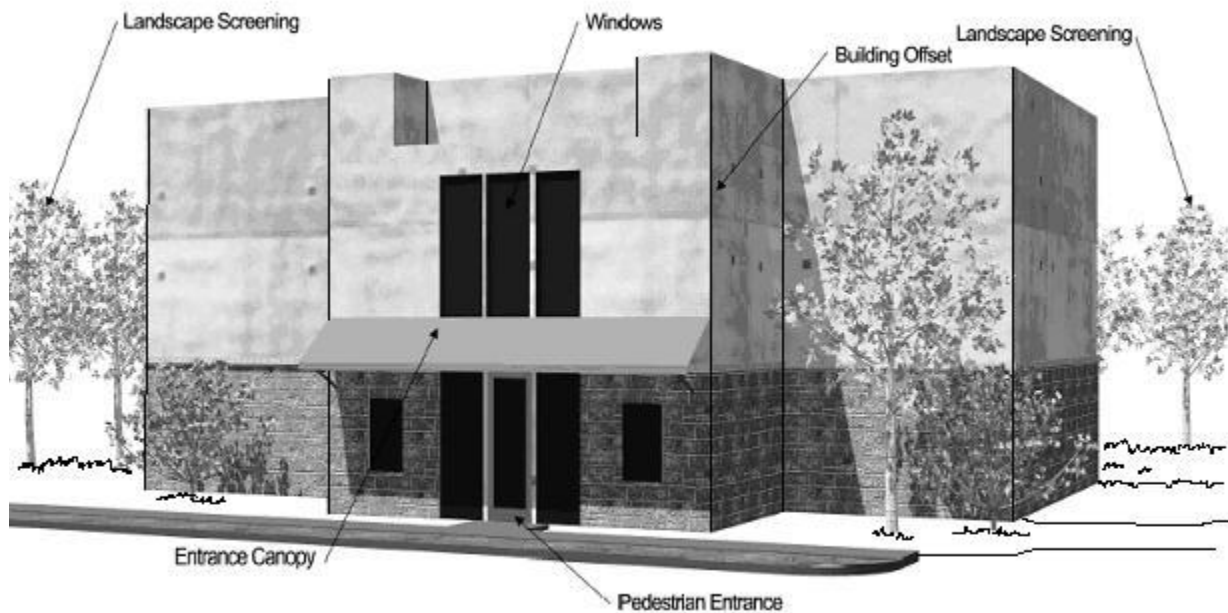

*Note: Figure above is intended to illustrate typical building design elements, and should not be interpreted as a required architectural style.*

- (g) **Standards for Certain Uses.** The Industrial Zones accommodate a range of manufacturing, industrial office uses, and secondary small-scale personal service Commercial Uses.
- (i) **Small Scale personal and professional services.** Small scale personal and professional service uses as specified in Table 8-1 must comply with the following development standards:

Lane Code  
CHAPTER 16 CONTENTS

- (aa) Small-scale personal and professional service uses may only be allowed when it is demonstrated that they will be secondary to the primary use of the building or development. No more than 2,500 square feet or 1% of the total square feet, whichever is greater, of a permitted use or use allowed with a Special Use Permit may be occupied by a secondary small-scale personal and professional service use.
- (ii) **Accessory Uses and Structures.** Accessory uses and structures are those of a nature customarily incidental and subordinate to the primary use or structure on the same lot. Typical accessory structures include detached garages, sheds, workshops, green houses and similar structures not intended for habitation by people. Accessory uses and structures are allowed for all permitted land uses within the Industrial Zones. All accessory structures must have a building permit if required and comply with all of the following development standards:
  - (aa) Primary use required. An accessory structure or use is not allowed on a lot before an allowed primary use is established.
  - (bb) Restrictions. Accessory uses and structures may not be placed over an easement where such placement would be inconsistent with use of the easement, and may not encroach into the public right-of-way.
  - (cc) Compliance with land division standards. The owner may be required to remove an accessory structure as a condition of land division approval when removal of the structure is necessary to comply with setback standards.
  - (dd) Setback Standards. Accessory structures must comply with the setback standards of the underlying zone.
- (iii) **Industrial Service uses in GI zone.** Industrial service uses are only allowed in the GI zone when secondary and subordinate to an approved primary use, and when the use is demonstrated to satisfy the following:
  - (aa) Create a job density of 13 jobs per net developed acre at build out of the proposed use.
- (iv) **Commercial/retail uses – existing properties with past commercial uses.** Commercial/retail uses are permitted on a property(ies) with a history of commercial/retail use where the primary use is located on property that prior to the date of the adoption of this section was under ¼ acre in size. The use is subject to other applicable sections of this chapter. Any modification, addition, or alteration of the previous use or structures related to the use is subject to the applicable provisions of this Section 16.280. Commercial/retail use is limited to 3000 square feet in size.
- (v) **Utilities.** Utility uses include the erection, construction, alteration, or maintenance of underground, overhead electrical, gas, steam or water transmission or distribution systems, collection, communication, supply or disposal system, including utility poles, wires, drains, sewers, pipes, conduits,

Lane Code  
CHAPTER 16 CONTENTS

cables and other similar equipment and accessories located outside of the public right of way.

Utility uses are only those conducted or operated by a public utility of municipal or other governmental agencies or licensed franchise.

Utility poles may exceed the height limits otherwise provided for in the applicable zone. In considering an application for a public or licensed franchise utility use, the Approval Authority must determine that all utility poles, overhead wires, pumping stations, equipment shelters and similar gear are located, designed and installed as to minimize their visual impacts. The Approval Authority may require screening as a condition of approval.

- (vi) **Corporate Office/Headquarters.** Corporate Office/Headquarters use is only allowed when directly associated with and subordinate to a primary permitted use or use allowed with a Special Use Permit on the same site. The portion of the corporate office/headquarter use must not exceed 25% of the square footage of the total building size for the entire primary use.
- (vii) **Warehouse, Freight Movement, and Distribution.** Warehouse, Freight Movement, and Distribution use is allowed in the GI zone when it is secondary and subordinate to an approved primary use OR allowed as a primary use when it is demonstrated to satisfy the following:
  - (aa) Create a job density of 13 jobs per net developed acre at build out of the proposed use.
  - (bb) Create jobs that pay no less than an average of 150% of the median wage.
  - (cc) Demonstrate that they are Rail Dependent, as defined in LC 16.280 above.

**(10) Access and Circulation**

- (a) **Purpose.** The purpose of this subsection, Access and Circulation is to ensure that developments provide safe and efficient access and circulation for pedestrians and vehicles. The requirements of this subsection apply in addition to the provisions of Lane Code Chapter 15.
- (b) **Vehicular Access and Circulation**
  - (i) **Access.** The access and facility permit provisions of Lane Code 15 must be met.
  - (ii) **Construction**
    - (aa) **Surface Options.** On site driveways, parking areas, aisles, and turnarounds may be paved with asphalt, concrete, or comparable surfacing, or a durable non-paving or porous paving material may be used to reduce surface water runoff and protect water quality. Driveway and street materials may be subject to review and approval by the County Engineer.

Lane Code  
CHAPTER 16 CONTENTS

**(bb) Stormwater Management.** When non-porous paving is used, all driveways, parking areas, aisles, and turnarounds must have on-site collection of surface waters to eliminate sheet flow of such waters onto public rights-of-way and abutting property. Surface water facilities must be constructed in conformance with subsection (16)(d), Stormwater Management Requirements, and applicable engineering standards.

**(c) Pedestrian Access and Circulation**

**(i) Site Layout and Design.** To ensure safe, direct, and convenient pedestrian circulation, all developments must provide a continuous pedestrian system. The pedestrian system must be designed to meet the standards below:

**(aa) Continuous Walkway System.** An on-site pedestrian walkway system must connect within the development according to (cc)(A-C) below, and connect to any future phases of development, and to any existing or planned off-site abutting trails, public parks, and open space areas unless approved through a Special Use Permit. The developer may also be required to connect or stub walkway(s) to abutting streets and to private property with a previously reserved public access easement for this purpose, in accordance with the provisions of subsection (10)(b), Vehicular Access and Circulation, and subsection (16)(b), Roads.

**(bb) Safe, Direct, and Convenient.** Walkways within developments must provide safe, reasonably direct, and convenient connections between primary building entrances and all abutting streets, based on the following definitions:

**(A) Reasonably direct.** A route that does not deviate unnecessarily from a straight line or a route that does not involve a significant amount of out-of-direction travel for users.

**(B) Safe and convenient.** Routes that are reasonably free from hazards and provide a reasonably direct route of travel between destinations.

**(C) "Primary entrance"** for commercial, industrial, mixed use, public, and institutional buildings is the main public entrance to the building. In the case where no public entrance exists, street connections must be provided to the main employee entrance.

**(cc) Connections within Development.** Connections within developments must be provided as required in subsections (A)-(C), below:

**(A)** Walkways must connect all building entrances to one another, as generally shown in Figures 10-1 through 10-3;

**(B)** Walkways must connect all on-site parking areas, storage areas, recreational facilities and common areas, and must connect public off-site abutting uses to the site. Topographic or existing development constraints may be cause for not making certain walkway connections;

Lane Code  
CHAPTER 16 CONTENTS

- (C) Large parking areas must be broken up so that no contiguous parking area exceeds three (3) acres. Parking areas may be broken up with plazas, large landscape areas with pedestrian access ways (*i.e.*, at least 20 feet total width), streets, or driveways with street-like features. Street-like features, for the purpose of this subsection, means a raised sidewalk of at least 4-feet in width, 6-inch curb, accessible curb ramps, street trees in planter strips or tree wells, and pedestrian-oriented lighting.

Figure 10-1 - Pedestrian Walkway System (Typical)

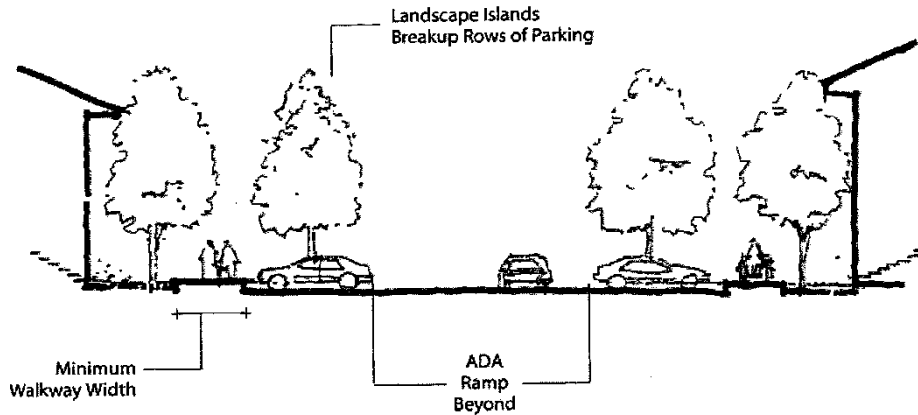
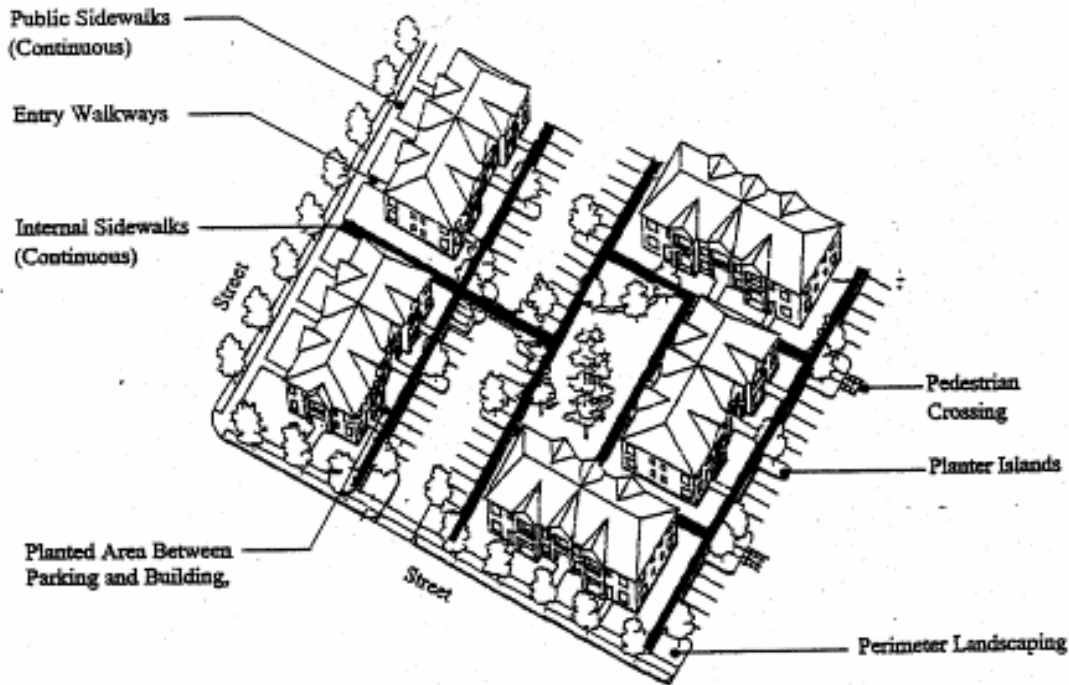

Figure 10-2 - Pedestrian Walkway System (Typical)



(ii) **Walkway Design and Construction.** Walkways, including those provided with pedestrian access ways, must conform to all of the standards in subsections (aa)-(dd) below, as generally illustrated in Figures 10-1 through 10-3:

(aa) **Vehicle/Walkway Separation.** Except for crosswalks, where a walkway abuts a driveway or street, walkways must be raised 6 inches and curbed along the edge of the driveway/street. Alternatively, the decision body may approve a walkway abutting a driveway at the same grade as the driveway if the walkway is protected from all vehicle maneuvering areas. An example of such protection is a row of decorative metal or concrete bollards designed to withstand a vehicle's impact, with adequate minimum spacing between them to protect pedestrians.

Lane Code  
CHAPTER 16 CONTENTS

- (bb) **Crosswalks.** Where walkways cross a parking area, driveway, or street (“crosswalk”), they must be clearly marked with contrasting paving materials (*e.g.*, light-color concrete inlay between asphalt), which may be part of a raised/hump crossing area. Painted or thermo-plastic striping and similar types of non-permanent applications may be approved for crosswalks not exceeding 24 feet in length.
- (cc) **Walkway Width and Surface.** Walkway and accessway surfaces must be concrete, asphalt, brick/masonry pavers, or other durable surface, as approved by the County Engineer, at least six (6) feet wide. Multi-use paths (*i.e.*, for bicycles and pedestrians) must be concrete or asphalt, at least 10 feet wide.
- (dd) **Accessible routes.** Walkways must comply with applicable Americans with Disabilities Act (ADA) requirements. The ends of all raised walkways, where the walkway intersects a driveway or street must provide ramps that are ADA accessible, and walkways must provide direct routes to primary building entrances.

Figure 10-3 - Pedestrian Walkway Detail (Typical)

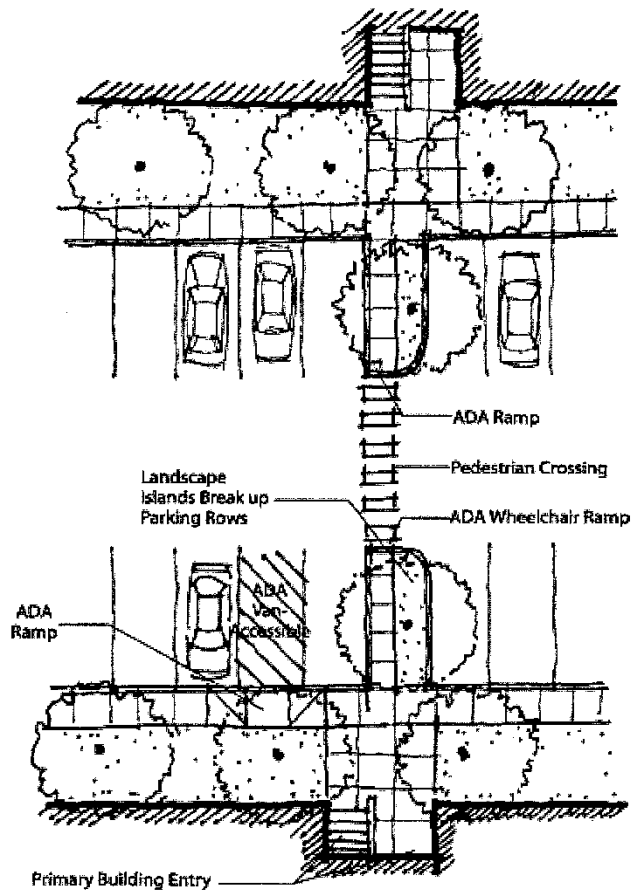

Lane Code  
CHAPTER 16 CONTENTS

**(11) Landscaping, Fences, Walls and Screening**

**(a) Purpose.** The purpose of this subsection, Landscaping, Fences, Walls and Screening is to promote community health, safety, and welfare by setting development standards for landscaping, fences, walls and screening. Together, these elements of the natural and built environment contribute to the visual quality, environmental health, and character of the community. Trees provide climate control through shading during summer months and wind screening during winter. Trees and other plants can also buffer pedestrians from traffic. Walls, fences, trees, and other landscape materials also provide vital screening and buffering between land uses. Landscaped areas help to control surface water drainage and can improve water quality, as compared to paved or built surfaces.

**(b) Landscaping**

**(i) Applicability.** This subsection applies to all new developments requiring Site Design Review.

**(ii) Landscaping Plan Required.** Submittal of a landscape plan is required. All landscape plans must conform to the requirements in subsection (6)(e)(i)(ee) (Landscape Plans).

**(iii) Landscape Area Standards.** The minimum percentage of required landscaping equals:

**(aa) General Industrial (GI) Zone.** 20 percent of the site.

**(bb) Light Industrial (LI) Zone.** 10 percent of the site.

**(iv) Landscape Materials.** Permitted landscape materials include trees, shrubs, ground cover plants, non-plant ground covers, and outdoor hardscape features, as described below. “Coverage” is based on the projected size of the plants at maturity, i.e., typically three (3) or more years after planting.

**(aa) Existing Vegetation.** Existing non-invasive vegetation may be used in meeting landscape requirements. When existing mature trees are protected on the site (e.g., within or abutting to parking areas) the applicant is permitted to reduce the number of new trees required by a ratio of one (1) inch caliper of new tree(s) for every one (1) inch caliper of existing tree(s) protected.

**(bb) Plant Selection.** A combination of deciduous and evergreen trees, shrubs, and ground covers must be used for all planted areas, the selection of which must be based on local climate, exposure, water availability, and drainage conditions. When new vegetation is planted, soils must be amended, as necessary, to allow for healthy plant growth.

**(cc) Non-native, invasive plants.** Non-native, invasive plants must be removed during site development and the planting of new invasive species is prohibited.



Lane Code  
CHAPTER 16 CONTENTS

- (dd) **Hardscape features.** Includes patios, decks, plazas and similar features. These features may cover up to ten 10 percent of the required landscape area.
- (ee) **Ground Cover Standard.** All landscaped areas, whether or not required, that is not planted with trees and shrubs, or covered with non-plant material, must have ground cover plants that are sized and spaced as follows: a minimum of one plant per 12 inches on center in triangular spacing, or other planting pattern that is designed to achieve 75 percent coverage of the area not covered by shrubs and tree canopy within three (3) years of planting.
- (ff) **Tree Size.** Trees must have a minimum diameter or caliper 4 feet above grade of two [2] inches or greater at time of planting.
- (gg) **Shrub Size.** Shrubs must be planted from a minimum of 3 gallon containers or larger.
- (hh) **Non-plant Ground Covers.** Bark dust, chips, aggregate, or other non-plant ground covers may be used, but must cover no more than 25 percent of the area to be landscaped and must be confined to areas underneath plants. Non-plant ground covers cannot be a substitute for ground cover plants.
- (ii) **Stormwater Management Facilities.** Stormwater management facilities (e.g., detention/retention ponds and swales designed for water quality treatment), when required under subsection (16)(d), must be landscaped in accordance with the design requirements of that subsection.
- (v) **Landscape Design Standards.** All yards, parking lots, and required street tree planter strips must be landscaped to provide, as applicable, erosion control, visual interest, buffering, privacy, open space and pathway identification, shading, and wind buffering, based on the following criteria:
  - (aa) **Yard Setback Landscaping.** Landscaping in yards must:
    - (A) Provide visual screening and privacy within side and rear yards; while leaving front yards and building entrances mostly visible for security purposes;
    - (B) Use shrubs and trees as wind breaks where appropriate;
    - (C) Define pedestrian pathways and open space areas with landscape materials where appropriate;
    - (D) Provide focal points within a development, for example, by preserving large or unique trees or groves, hedges, and flowering plants where appropriate;
    - (E) Use trees to provide summer shading within common open space areas and within front yards when street trees cannot be provided;

Lane Code  
CHAPTER 16 CONTENTS

- (F) Use a combination of plants for year-long color and interest;
- (G) Screen outdoor storage and mechanical equipment areas in accordance with subsection (11)(d) below, and to enhance graded areas such as berms, swales, and detention/retention ponds or swales.

- (bb) **Parking areas.** A minimum of 10 percent of the total surface area of all parking areas, as measured around the perimeter of all parking spaces and maneuvering areas, must be landscaped. Such landscaping must consist of “evenly distributed” shade trees where practical, with shrubs and/or ground cover plants that conform to the criteria in subsection (11)(b)(iv)(aa-ii) above.

“Evenly distributed” means that the trees and other plants are distributed around the parking lot perimeter and between parking bays to provide a partial canopy where practical. Required trees may be clustered to provide visual interest. At a minimum, one tree per 6 parking spaces on average must be planted to create a partial tree canopy over and around the parking area. All parking areas with more than 50 spaces must include landscape islands with trees to break up the parking area so that no parking space is more than 70 feet away from a landscape island. All parking area landscape beds must have dimensions of not less than 24 square feet of area, or not less than 4 feet in width by 6 feet in length, to ensure adequate soil, water, and space for healthy plant growth.

- (cc) **Parking/Maneuvering Area Abutting to Building.** Where a parking or maneuvering area, or driveway, is abutting to a building, the area must be separated from the building by a curb and a raised walkway, plaza, or landscaped buffer not less than 5 feet in width along the length of the abutting area. Raised curbs, bollards, wheel stops, or other design features must be used to protect pedestrians, landscaping, and buildings from being damaged by vehicles.

(vi) **Buffering**

- (aa) A 20-foot minimum buffer zone is required between Industrial development in either the GI or LI zone and any abutting residential or resource zoned property. The buffer zone must be landscaped according to the landscaping provisions of this subsection to screen industrial activities such as parking, service and delivery areas, from residential or resource zones. The buffer must not contain any trash receptacles or storage of equipment, materials, vehicles, or mechanical equipment, etc.

For uses that require a Special Use Permit, the approval body may require landscaping, fences, walls or other buffering that exceed the landscaping standards in this subsection when it finds through Special Use Permit review, subsection (7), that additional or different buffering is necessary to mitigate adverse impacts from parking, traffic, noise, vibration, exhaust/emissions, light, glare, erosion, odor, dust, visibility, safety, and aesthetic considerations to and protect the privacy.

Lane Code  
CHAPTER 16 CONTENTS

- (bb) **Pedestrian Access.** The approval body may require the construction of pedestrian access ways through required buffers to ensure pedestrian connections within large developments, between multiple development phases, or connecting to public sidewalks, walkways, or multi-use pathways. The design of access ways must conform to subsection (10), Parking and Loading.
- (vii) **Maintenance and Irrigation.** The use of drought-tolerant plant species is encouraged. Irrigation must be provided. If the plantings fail to survive, the property owner must replace them within 6 months with an equivalent specimen (i.e., evergreen shrub replaces evergreen shrub, deciduous tree replaces deciduous tree, etc.). All human-made features required by this Chapter must be maintained in good condition, or otherwise replaced by the owner.
- (c) **Fences and Walls.** Construction of fences and walls must conform to all of the following requirements:

  - (i) **General Requirements.** All fences and walls must comply with the development standards and height limitations of the respective zone, subsection (9) Development Standards, and the standards of this subsection. The County may require installation of walls and/or fences as a condition of development approval, in accordance with land division approval (e.g., flag lots), approval of a Special Use Permit, or Site Design Review approval. When required through one of these types of approvals, no further land use review is required. If not part of a prior land use approval, new fences and walls require Land Use Review approval; if greater than 6 feet in height, a building permit is also required.
  - (ii) **Dimensions**

    - (aa) Except as provided under subsection (11)(d), Screening, below, the height of fences and walls within a front yard setback is limited to 4 feet as measured from the grade closest to the street right-of-way.
    - (bb) A retaining wall exceeding 4 feet in height within a front yard setback, which is necessary for site grading and development, may be approved through a land division or Site Design Review.
    - (cc) One arbor, gate, or similar garden structure not exceeding 8 feet in height and 4 feet in width is allowed within the front yard, provided that it is not within a clear vision triangle, unless approved through a Special Use Permit.
    - (dd) Fences and walls must comply with the vision clear zone of Lane Code (LC) 15.095(3) and as defined in LC 15.010(40).
  - (iii) **Maintenance.** For safety and for compliance with the purpose of this subsection, walls and fences required as a condition of development approval must be maintained in good condition, or otherwise replaced by the property owner.
  - (iv) **Materials**

Lane Code  
CHAPTER 16 CONTENTS

- (aa) Permitted fence and wall materials: wood; metal; bricks, stone; stucco, or similar masonry, and non-prohibited evergreen plants.
  - (bb) Prohibited fence and wall materials: concrete blocks; straw bales; barbed or razor wire; scrap lumber, metal, or other scrap materials; hedges higher than 8 feet.
  - (cc) Fences or walls that are taller than 6 feet may require a building permit.
- (v) **Fencing**
- (aa) **Perimeter Fencing.** Lot perimeter fencing is only permitted within the Industrial zones under the conditions set forth in Table 11-1, Fencing Conditions.
  - (bb) **Standard Fencing.** Standard non-decorative fencing may be installed in areas not visible from street rights of way or adjoining properties within the Industrial zones. Standard fencing also may be used as specified in Table 9-1. A minimum quality of standard fencing is black vinyl-coated chain link.
  - (cc) **Upgraded Fencing.** Upgraded fencing must be provided as specified in Table 11-1. Upgraded fencing is intended to provide limited security, discourage trespass, and provide an informative demarcation between uses (e.g., public / private, institutional / private / public, etc.). Design considerations for upgraded fencing must include:
    - (A) Simplicity as opposed to excessive ornamentation.
    - (B) Low maintenance / ease of landscape maintenance on each side.
    - (C) Respect for the design theme of established development on abutting parcels.
    - (D) A clear relationship to the building's architecture.
    - (E) Consideration of a standard design where a large property shares a common boundary with several smaller properties.
  - (dd) **Architectural Screen Walls.** Architectural screen walls must be used to screen service and loading areas; above-ground utilities such as transformers and generators, exterior material and equipment storage areas, work yards, and trash and/or recycling areas. Architectural screen walls may be used to screen other on-site amenities such as private patios and employee break areas. Architectural screen walls must be integrated into the overall building architectural statement, employing materials and colors drawn from the building design palette. The required size of an area enclosed by an architectural screen wall is the minimum necessary to accommodate the facility or operation that is to be screened.
- (vi) **Fencing on Steep Slopes.** Properties with more extreme variations in topography (e.g., substantial slopes abutting to relatively flat areas) must employ fencing and/or screening design approaches that are thoughtfully integrated with the site's unique characteristics while fulfilling the overall functional intent of these features. Stair-step fence profiles are not allowed.

Lane Code  
CHAPTER 16 CONTENTS

**Table 11-1 Fencing Conditions**

Condition	Sub-condition	Required Treatment (Minimum Standard)
Property line adjacent to a public right of way.	Improved right of way.	Upgraded fencing.
	Unimproved right of way.	No requirement prior to development.
Property line adjacent to the railroad right of way.		Standard Fencing.
Property line on the west or south perimeter of the Goshen Industrial area.	Adjacent to residential or resource zoned property.	Standard Fencing.
	Adjacent to Commercial zoned property.	Upgraded Fencing.
	Adjacent to permanent open space.	Upgraded Fencing.
	Adjacent to Public Facility zoned property.	Standard Fencing
Property line adjacent to a park or open space.		Upgraded Fencing.
Property line on the east perimeter of the Goshen Industrial area.	Adjacent to residential or resource zoned property.	Upgraded Fencing.
	Adjacent to commercial zoned property.	Upgraded Fencing.
Fencing/Screening around a Loading or Exterior storage area.	Visible from the right of way.	Architectural Screen Wall.
	Not visible from the right of way.	Standard Fencing.
Screening around a trash and/or recycling enclosure or exterior storage.		Architectural Screen Wall.
Fencing around a secure parking lot.	Visible from the right of way.	Upgraded Fencing.
	Not visible from the right of way.	Standard Fencing.

**(d) Screening**

**Screening Required.** Screening is required under the following conditions:

- (i) **Screening of Mechanical Equipment, Outdoor Storage, Service and Delivery Areas.** All mechanical equipment, outdoor storage and manufacturing, and service and delivery areas, must be screened from view from all abutting public streets and abutting residential or resource zones. This required screening is required to be a minimum of 6 feet in height and provided by:
  - (aa) a decorative wall (i.e., masonry or similar quality material);
  - (bb) evergreen hedge;
  - (cc) opaque fence complying with subsection (11)(c); or
  - (dd) a similar feature that provides an opaque barrier.

Walls, fences, and hedges must comply with the vision clearance requirements of Lane Code (LC) 15.095(3) and as defined in LC 15.010(40) and provide for pedestrian circulation, in accordance with subsection (10), Access and Circulation.

- (ii) **Parking/Maneuvering Area Abutting Streets and Drives.** Where a parking or maneuvering area is abutting and parallel to a street or driveway, an evergreen

Lane Code  
CHAPTER 16 CONTENTS

hedge; decorative wall (masonry or similar quality material) with openings; or arcade, trellis, or similar partially opaque structure 3-4 feet in height is required between the parking or maneuvering area and the street or driveway. The required screening must have breaks, where necessary, to allow pedestrians access to the site. The design of the wall or screening must also provide breaks or openings for visual surveillance of the site and security. Evergreen hedges used to comply with this standard must be a minimum of 36 inches in height within three (3) years of planting, and must be of such species, number, and spacing to provide the required screening within three (3) years after planting. Any areas between the wall/hedge and the street/driveway line must be landscaped with plants or other vegetative ground cover.

- (iii) **Flag Lot Screen.** In approving a flag lot, the County may require a landscape screen, fence or both be installed along property line(s) of the flag lot, for privacy of adjoining property, in accordance with the provisions of this subsection. A flag lot screen is not required if the abutting property owner(s) indicate in writing that they do not want a screen or fence, however, the owner may install one at the owner's discretion.

**(12) Parking and Loading**

- (a) **Purpose.** The purpose of this subsection, Parking and Loading, is to provide basic and flexible standards for development of vehicle and bicycle parking. The design of parking areas is critically important to the economic viability of some employment areas, pedestrian and driver safety, the efficient and safe operation of adjoining streets, and community image and livability. Historically, some communities have required more parking than is necessary for some land uses, paving extensive areas of land that could be put to better use. Because vehicle parking facilities occupy large amounts of land, they must be planned and designed carefully to use the land efficiently, minimize stormwater runoff, and maintain the visual character of the community. This subsection recognizes that each development has unique parking needs and provides a flexible approach for determining parking space requirements (i.e., "minimum" and "performance-based" standards). This subsection also provides standards for bicycle parking because many people use bicycles for recreation, commuting, and general transportation. Children as well as adults need safe and adequate spaces to park their bicycles throughout the community.
- (b) **Applicability.** All developments subject to Site Design Review, subsection (6) including development of parking facilities, must comply with the provisions of this subsection.
- (c) **Automobile Parking Standards**
  - (i) **Vehicle Parking - Minimum Standards by Use.** The number of required off-street vehicle parking spaces must be determined in accordance with the standards in Table 12-1, or alternatively, through a separate parking demand analysis prepared by the applicant and subject to a Special Use Permit approval. Where a use is not specifically listed in this table, parking requirements are determined by finding that a use is similar to one of those listed in terms of parking needs, or by estimating parking needs individually using the demand analysis option described above. Parking that counts toward the minimum requirement is parking in garages, carports, parking lots, bays along driveways, shared parking, and designated on-street parking.

Lane Code  
CHAPTER 16 CONTENTS

**Table 12-1 – Minimum Required Parking by Use**

<b>Use Categories</b> <i>(Examples of uses are in Chapter 1.4; definitions are in Chapter 1.3.)</i>	<b>Minimum Parking per Land Use</b> (fractions rounded down to the closest whole number)
<b>Commercial Categories</b>	
Offices	2 spaces per 1,000 sq. ft. floor area
Self-Service Storage	No standard
<b>Industrial Categories</b>	
Industrial Service	1 space per 1,000 sq. ft. of floor area
Manufacturing and Production	1 space per 1,000 sq. ft. of floor area
Warehouse and Freight Movement	0.5 space per 1,000 sq. ft. of floor area
Wholesale Sales	1 space per 1,000 sq. ft. per SUP review (subsection (7))
- fully enclosed	
- not enclosed	

**(ii) Vehicle Parking - Minimum Accessible Parking**

- (aa)** Accessible parking must be provided for all uses in accordance the standards in Table 12-2; parking spaces used to meet the standards in Table 12-2 are counted toward meeting off-street parking requirements in Table 12-1;
- (bb)** Such parking must be located in close proximity to building entrances and must be designed to permit occupants of vehicles to reach the entrance on an unobstructed path or walkway;
- (cc)** Accessible spaces must be grouped in pairs where possible;
- (dd)** Where covered parking is provided, covered accessible spaces must be provided in the same ratio as covered non-accessible spaces;
- (ee)** Required accessible parking spaces must be identified with signs and pavement markings identifying them as reserved for persons with disabilities; signs must be posted directly in front of the parking space at a height of no less than 42 inches and no more than 72 inches above pavement level. Van spaces must be specifically identified as such.

THIS SPACE INTENTIONALLY LEFT BLANK

Lane Code  
CHAPTER 16 CONTENTS

**Table 12-2 - Minimum Number of Accessible Parking Spaces**  
(Source: ADA Standards for Accessible Design)

Total Number of Parking Spaces Provided (per lot)	Total Minimum Number of Accessible Parking Spaces (with 60" access aisle, or 96" aisle for vans*)	Van Accessible Parking Spaces with min. 96" wide access aisle	Accessible Parking Spaces with min. 60" wide access aisle
	<i>Column A</i>		
1 to 25	1	1	0
26 to 50	2	1	1
51 to 75	3	1	2
76 to 100	4	1	3
101 to 150	5	1	4
151 to 200	6	1	5
201 to 300	7	1	6
301 to 400	8	1	7
401 to 500	9	2	7
501 to 1000	2% of total parking provided in each lot	1/8 of Column A**	7/8 of Column A***
1001	20 plus 1 for each 100 over 1000	1/8 of Column A**	7/8 of Column A***
*vans and cars may share access aisles			
**one out of every 8 accessible spaces		***7 out of every 8 accessible parking spaces	

(iv) **On-Street Parking.** On-street parking must conform to the following standards:

(aa) **Dimensions.** The following constitutes one on-street parking space:

- (A) Parallel parking, each 22 feet of uninterrupted curb;
- (B) 45 degree diagonal, each with 12 feet of curb;
- (C) 90 degree (perpendicular) parking, each with 12 feet of curb.

(bb) **Location.** Parking may be counted toward the minimum standards in Table 12-1 when it is on the block face abutting the subject land use. On-street parking spaces must be located such that when occupied they do not obstruct a required clear vision area and do not violate any law or street standard.

(cc) **Public Use Required for Credit.** On-street parking spaces counted toward meeting the parking requirements of a specific use may not be used exclusively by that use, but must be available for general public use at all times. Signs or other actions that limit general public use of on-street spaces are prohibited.

(v) **Shared parking.** Required parking facilities for two or more uses, structures, or parcels of land may be satisfied by the same parking facilities used jointly, to the extent that the owners or operators show that the need for parking facilities does



Lane Code  
CHAPTER 16 CONTENTS

not materially overlap (e.g., uses primarily of a daytime versus nighttime nature; weekday uses versus weekend uses), and provided that the right of joint use is evidenced by a recorded deed, lease, contract, or similar written instrument establishing the joint use. The County may approve owner requests for shared parking through Land Use Review.

- (vi) **Off-site parking.** Except for single-family dwellings, the required vehicle parking spaces may be located on another parcel of land, provided the parcel is within  $\frac{1}{4}$  mile of the use it serves and the County has approved the off-site parking through a Special Use Permit. The distance from the parking area to the use is measured from the nearest parking space to a building entrance, following a sidewalk or other pedestrian route. The right to use the off-site parking must be evidenced by a recorded deed, lease, easement, or similar written instrument.
  
- (vii) **General Parking Standards**
  - (aa) **Location.** Parking is allowed only on streets, within garages, carports, and other structures, or on driveways or parking lots that have been developed in conformance with this code. Subsection (10), Access and Circulation, provides design standards for driveways. Street parking spaces must not include space in a vehicle travel lane (including emergency or fire access lanes), pedestrian accessway, landscape, or other undesignated area.
  
  - (bb) **Mixed uses.** If more than one type of land use occupies a single structure or parcel of land, the total requirements for off-street automobile parking is the sum of the requirements for all uses, unless it can be shown that the peak parking demands are actually less (e.g., the uses operate on different days or at different times of the day). The County may reduce the total parking required accordingly through Site Design Review.
  
  - (cc) **Availability of facilities.** Owners of off-street parking facilities may post a sign indicating that all parking on the site is available only for residents, customers, and/or employees. Signs must conform to the standards of subsection (15), Signs.
  
  - (dd) **Lighting.** Parking areas must have lighting to provide at least 2 foot-candles of illumination over parking spaces and walkways. Lighting must meet the requirements of subsection (14), Outdoor Lighting Standards.
  
  - (ee) **Screening of Parking Areas.** Parking spaces must be located or screened so that headlights do not shine onto abutting residential or resource uses. Screening for this purpose must meet the requirements of subsection (11)(d), Screening.
  
  - (ff) **Parking and Loading Setback.** Where an Industrial zone abuts a residential or resource zone, any off-street parking and loading areas must be set back at least 20 feet from the abutting residential or resource property line and the setback area must be landscaped to provide a buffer

Lane Code  
CHAPTER 16 CONTENTS

along the adjoining residential or resource property. Landscaping must be maintained by the property owner and must meet the standards of subsections (11)(b), Landscaping.

- (gg) **Parking and Circulation.** No vehicle circulation or parking except for access driveways must be permitted within any required minimum front yard setback area.
  
- (viii) **Parking Stall Design and Minimum Dimensions.** All off-street parking spaces must be improved to conform to County standards for surfacing, stormwater management, and striping or as otherwise allowed in Chapter 16.280. Standard parking spaces must conform to the following standards:
  - (aa) Motor vehicle parking spaces must measure eight (8) feet six (6) inches wide by eighteen (18) feet long or by sixteen (16) feet long, with not more than a two (2) foot overhang when allowed;
  - (bb) All parallel motor vehicle parking spaces must measure eight (8) feet six (6) inches by twenty-two (22) feet;
  - (cc) Parking area layout must conform to the dimensions in Figure 12-1 and 12-2, and Table 12-3 below;
  - (dd) Parking areas must conform to Americans with Disabilities Act (ADA) standards for parking spaces (dimensions, van accessible parking spaces, etc.). Parking structure vertical clearance, van accessible parking spaces, should refer to Federal ADA guidelines; and
  - (ee) Bicycle parking must be on a two (2) feet by six (6) feet minimum concrete pad per bike, or within a garage or patio of residential use. Bicycle parking must consist of a securely fixed structure that supports the bicycle frame in a stable position without damage to wheels, frame, or components and that allows the frame and both wheels to be locked to the rack by the bicyclist's own locking device.

**Figure 12-1 - Parking Area Layout**

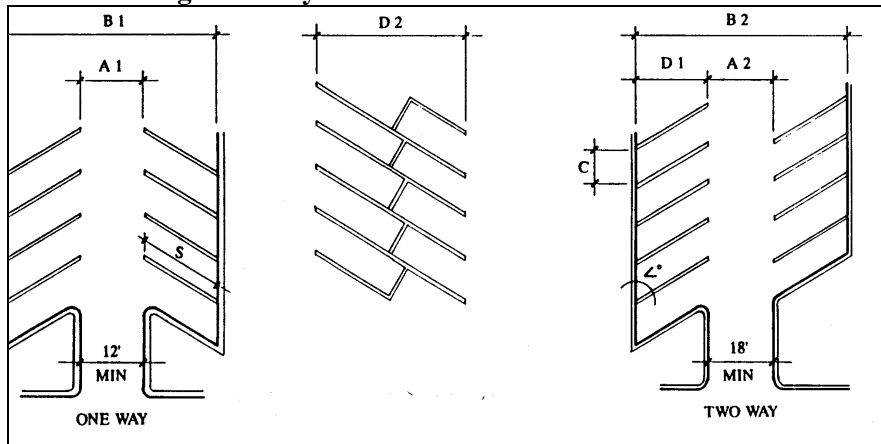

**Figure 12-2 ADA Parking Requirements**

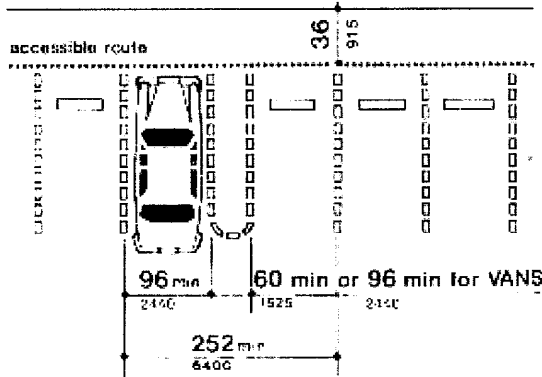

**Table 12-3 - Parking Area Layout**

Standard Space  (See Figure 10-2 for ADA space requirements)	PARKING ANGLE	CURB LENGTH	STALL DEPTH		AISLE WIDTH		BAY WIDTH		STRIPE LENGTH
			SINGLE D1	DOUBLE D2	ONE WAY A1	TWO WAY A2	ONE WAY B1	TWO WAY B2	
	90°	8'-6"	18'	36'	23'	23'	59'	59'	18'
	60°	10'	20'	40'	17'	18'	57'	58'	23'
	45°	12'	18'-6"	37'	13'	18'	50'	55'	26'-6"
	30°	17'	16'-6"	33'	12'	18'	45'	51'	32'-8"
	0°	22'	8'-6"	17'	12'	18'	29'	35'	8'-6"

**Important cross-references:**

See also subsection (10), Access and Circulation, for driveway standards; subsection (11), Landscaping, Fences, Walls and Screening; and subsection (16)(d), Stormwater Management.

- (d) **Bicycle Parking Requirements.** All uses that are subject to Site Design Review must provide bicycle parking, in conformance with the standards in Table 12-4, and subsections (i-viii), below.
  - (i) **Minimum Required Bicycle Parking Spaces.** Uses must provide long- and short-term bicycle parking spaces, as designated in Table 12-4. Where two options are provided (e.g., 2 spaces, or 1 per 12,000 square feet of floor area), the option resulting in more bicycle parking is used.

THIS SPACE INTENTIONALLY LEFT BLANK

Lane Code  
CHAPTER 16 CONTENTS

**Table 12-4 - Minimum Required Bicycle Parking Spaces**

Use Categories	Specific Uses	Long-term Spaces (covered or enclosed)	Short-term Spaces (near building entry)
<b>Commercial Categories</b>			
Retail Sales And Service		2, or 1 per 12,000 sq. ft. of floor area	2, or 1 per 5,000 sq. ft. of floor area
Office		2, or 1 per 10,000 sq. ft. of floor area	2, or 1 per 40,000 sq. ft. of floor area
<b>Industrial Categories</b>			
Manufacturing And Production		2, or 1 per 15,000 sq. ft. of floor area	None
Warehouse And Freight Movement		2, or 1 per 40,000 sq. ft. of floor area	None

- (ii) **Exemptions.** This subsection does not apply to single-family and two-family housing (attached, detached, or manufactured housing), home occupations, agriculture and livestock uses.
  - (iii) **Location and Design.** Bicycle parking should be no farther from the main building entrance than the distance to the closest vehicle space, or 50 feet, whichever is less. Long-term (i.e., covered) bicycle parking should be incorporated whenever possible into building design. Short-term bicycle parking, when allowed within a public right-of-way, should be coordinated with the design of street furniture, as applicable. Bicycle parking must consist of a securely fixed structure that supports the bicycle frame in a stable position without damage to wheels, frame, or components and that allows the frame and both wheels to be locked to the rack by the bicyclist's own locking device;
  - (iv) **Visibility and Security.** Bicycle parking for customers and visitors of a use must be visible from street sidewalks or building entrances, so that it provides sufficient security from theft and damage;
  - (v) **Options for Storage.** Long-term bicycle parking requirements for employee parking can be met by providing a bicycle storage room, bicycle lockers, racks, or other secure storage space inside or outside of the building;
  - (vi) **Lighting.** For security, bicycle parking must be at least as well lit as vehicle parking.
  - (vii) **Reserved Areas.** Areas set aside for bicycle parking must be clearly marked and reserved for bicycle parking only.
  - (viii) **Hazards.** Bicycle parking must not impede or create a hazard to pedestrians. Parking areas must be located so as to not conflict with any vision clear zone.
- (e) **Loading Areas**
- (i) **Purpose.** The purpose of this subsection of the Code is to provide standards (1) for a minimum number of off-street loading spaces that will ensure adequate loading areas for large uses and developments, and (2) to ensure that the appearance of loading areas is consistent with that of parking areas.

Lane Code  
CHAPTER 16 CONTENTS

- (ii) **Applicability.** Subsection (12)(e) applies to non-residential and mixed-use buildings with 20,000 square feet or more total floor area.
- (iii) **Number of Loading Spaces**
  - (aa) Non-residential and mixed-use buildings. Buildings where any floor area is in non-residential uses must meet the following standards:
    - (i) Less than 20,000 square feet total floor area: No loading spaces required.
    - (ii) 20,000 to 50,000 square feet of total floor area: One loading space.
    - (iii) More than 50,000 square feet of total floor area: Two loading spaces.
  - (iv) **Size of Spaces.** Required loading spaces must be at least 35 feet long and 10 feet wide, and must have a height clearance of at least 13 feet.
  - (v) **Placement, setbacks, and landscaping.** Loading areas must conform to the setback and perimeter landscaping standards in subsection (9) Development Standards, and subsection (11) Landscaping, Fences, Walls and Screening. Where parking areas are prohibited between a building and the street, loading areas are also prohibited.

**(13) Noise Standards**

All new development must be designed and constructed so that operation of the uses on the property will comply with the State of Oregon Noise Control Regulations contained in Oregon Administrative Rule (OAR) 340-035-0005 thru 340-035-0100, where applicable. The County requires as an ongoing condition of approval that these standards are met.

**(14) Outdoor Lighting Standards**

- (a) **Purpose.** The purpose of this subsection, Outdoor Lighting Standards is to allow citizens, businesses, and public agencies in the community of Goshen to illuminate commercial, industrial, public areas, roadways and walkways with lighting fixtures appropriate to the need while using such illumination in a way that preserves vistas and is directed onto and is confined to the property from which the light is generated.
- (b) **Outdoor Lighting Fixtures Subject to this Ordinance.** Light fixtures subject to the standards in subsection (14)(c) are outdoor artificial illuminating devices, outdoor fixtures, lamps and other similar devices, permanently installed or portable, used for flood lighting, general illumination or advertisement. Such devices must include, but are not limited to, lights for:
  - (i) Buildings and structures;
  - (ii) Recreational areas;
  - (iii) Parking lot and maneuvering areas;
  - (iv) Landscape areas;

Lane Code  
CHAPTER 16 CONTENTS

- (v) Streets and street signs;
  - (vi) Product display area;
  - (vii) Building overhangs and open canopies;
  - (viii) Holiday celebrations;
  - (ix) Construction Lights;
- (c) **Standards for installation and operation of outdoor lighting.** Except as exempt by subsection (14)(d) new outdoor lighting fixtures installed after the effective date of this subsection, are subject to the standards below. No provision of this subsection is intended to pre-empt the Lane County Sign Code or applicable state codes.
- (i) All outdoor lighting fixtures subject to this subsection must be designed as a full cut-off fixture or have a shielding method to direct light emissions down onto the site and not shine direct illumination or glare onto abutting properties.
  - (ii) All lighting for roadways, roadway signs, intersections, and pedestrian ways must be designed or have an opaque shielding method to direct light emissions downward and below the horizontal plane of the fixture in the permanently installed position.
  - (iii) The use of laser source light or any similar high intensity light for outdoor advertising or entertainment is prohibited.
  - (iv) The operation of searchlights for advertising or promotional purposes is prohibited.
  - (v) Businesses and institutions with outdoor lighting, such as parking lot lights, building lights, landscaping lights and other similar exterior lighting features, are encouraged to extinguish such lights at the end of the working day, except for lights necessary for personal and building safety.
  - (vi) Externally affixed neon lighting is prohibited except in the following manner: As a trim element that surrounds windows, doors, or building edges; when located on building facades that face street frontages or internal driveways within commercial shopping complexes; such lighting must not be located more than 15 feet from finished grade and must not be used to define a building roof-line; and, such lighting must not include flashing, intermittent or rotating lights. Notwithstanding the provisions of this subsection, all neon lighting associated with signs must meet the requirements of the Lane County Sign Code.
- (d) **Exemptions.** The following light fixtures or uses are exempt from complying with the outdoor lighting standards of this ordinance. These exemptions do not prevent the County from adoption of later ordinances that may address the retrofitting or removal of outdoor lighting fixtures.
- (i) All outdoor light fixtures lawfully installed and operating prior to the effective date of this ordinance, and not prohibited by this ordinance. This exemption does not apply if an existing light fixture is replaced. The addition of supplementary shielding and/or re-aiming of existing fixtures that shine direct illumination or visible glare beyond the property line where the fixture is installed are encouraged to help improve safety and quality of life in the community of Goshen and the surrounding areas.

Lane Code  
CHAPTER 16 CONTENTS

- (ii) Commercial and industrial low wattage lighting used to highlight driveways and landscaping, or applied to a building providing they are properly aimed and shielded down to not shine visible glare, emit direct illumination, or cast a shadow into the public right of way or onto abutting or nearby properties.
  - (iii) Up-lighting intended to highlight part of a building or landscaping provided that the light distribution from the fixture is effectively contained by an overhanging architectural element or landscaping element and do not shine beyond the intended target including into the night sky. Such containment elements may include but are not limited to awnings, dense shrubs or year round dense evergreen tree canopies which will contain or limit illumination of the sky.
  - (iv) Low wattage lights used for holiday decorations for no more than 60 days are exempt from the requirements of this ordinance.
  - (v) Outdoor mass gatherings, as defined by ORS 433.735, that do not require a land use decision, that require the use of temporary outdoor lighting fixtures are exempt except that permanent installations at dedicated sites must conform to the requirements of this ordinance.
  - (vi) U.S. flags displayed by top mounted lighting only. The illumination of all flags other than the U.S. flag must be extinguished at the end of public business hours or by 10:00 PM whichever is later.
  - (vii) Temporary lighting for television or movie film productions, roadway or utility construction or building construction not to exceed 60 days in any one vicinity. Permanent installations at dedicated sites must conform to the requirements of this ordinance.
  - (viii) All outdoor light fixtures used to highlight art features within a traffic circle or round-about providing they are properly aimed and shielded to not shine visible glare into the public right of way or onto abutting or nearby properties.
- (e) **Definitions.** The following definitions apply to terms in this subsection.
- (i) End of business hours or End of business. “End of business hours or end of business” means the end of normal or posted business hours when a business or institution is no longer open to serve customers or clients, and (b) the end of a shift or normal work hours when the majority of employees are gone from the business or institution.
  - (ii) Full Cut-off. “Full Cut-off” means a light fixture designed and constructed so that light is directed down and no light is projected above the horizontal plane. [See figure 14-1 below]
  - (iii) Glare. “Glare” means stray, unshielded light striking the eye that may result in (a) nuisance or annoyance such as light shining into a window; (b) discomfort causing squinting of the eyes; (c) disabling vision by reducing the ability of the eyes to see into shadows; or (d) reduction of visual performance.

Lane Code  
CHAPTER 16 CONTENTS

- (iv) High intensity discharge lighting. "High intensity discharge lamp lighting" means high pressure sodium, mercury vapor, metal halide, low-pressure sodium, induction, sulfur, xenon, and other similar lamps.
- (v) Installed. "Installed" means initial installation of outdoor lighting fixtures, poles, electrical wiring, and related mounting equipment following the effective date of this ordinance. Projects with approved construction plans prior to effective date of this ordinance are excluded from compliance with the ordinance in the initial installation only.
- (vi) Low Wattage lights. "Low Wattage Lights" means 12-volt direct current lights or individual lamps less than 0.25 watts each strung together within a translucent or transparent plastic cover.
- (vii) Replacement. "Replacement" means the installation of a new lighting fixture in place of an existing fixture, and/or the installation of a new lighting housing or head to an existing pole, bracket or wall, tree, or other structure. Replacement does not mean the changing of light bulbs or lamps in a fixture for the same or lower wattage bulbs.
- (viii) Safety / security. "Safety" means (a) sufficient lighting at building entrances, exits, walkways and parking areas to allow customers and employees to see any physical barriers and to be seen at all times as they access to vehicles and sidewalks, and (b) the use of full cut-off light fixtures above doors, at fire service stanchions, loading areas, and similar building access points.
- (ix) Shielding. "Shielding" means an externally applied device such as a shroud or hood of metal, wood, opaque plastic or opaque painted glass so that light emitted by the fixture is directed downward below the horizontal plane onto the site and does not shine direct illumination or glare onto abutting or nearby property.
- (x) Unshielded. "Unshielded" means light fixtures lacking any means to restrict the emitted light to below the horizontal plane or to shine or glare onto abutting or nearby property.
- (xi) Up-lighting. "Up lighting" means a shielded light fixture usually installed on the ground or permanently mounted to an architectural element, tree, or other structure that has the light from the fixture directed in a contained distribution pattern above the horizontal plane to illuminate an abutting or nearby building element, shrub, tree or other landscaping.

**Figure 14-1 Examples of full cut off light fixtures (typical)**



Lane Code  
CHAPTER 16 CONTENTS



**(15) Signs**

- (a) Signs may not extend over a public right-of-way or project beyond the property line.
- (b) Signs may be illuminated but may not be flashing or capable of movement.
- (c) Signs may not exceed 100 square feet of surface area on any one of two sides.
- (d) Signs may not project above the height of the tallest structure on the property.
- (e) Signs may only advertise uses and development that are conducted on the same premises where the signs are located and that are permitted by LC 16.292(2) or (3) above.

**(16) Utility Facilities****(a) Purpose and Applicability**

- (i) **Purpose.** The purpose of this subsection, Utility Facilities is to provide planning and design standards for public or private utilities and easements for transportation, sewer, water, and storm drainage improvements.
- (ii) **When Standards Apply.** Unless otherwise provided, the standard specifications for construction, reconstruction, or repair of utilities, and other private improvements must comply with the standards of this subsection. Public and private facilities related to a particular development must comply with the public facility requirements established in this subsection.
- (iii) **Engineering Design Criteria, Standard Specifications and Details.** The County's specifications, standards, and details contained in Lane Manual 15.450 are hereby incorporated into this code by reference.
- (iv) **Conditions of Development Approval.** No development may occur unless required public facilities are in place or guaranteed, in conformance with the provisions of Lane Code. On-site improvements required as a condition of development approval, when not voluntarily accepted by the applicant, must be roughly proportional to the impact of the development on public facilities. Where on-site improvements are required, the Approval Authority must include findings in the development approval indicating how the required improvements are directly related and roughly proportional to the impact from the proposed development.

**(b) Roads**

Development subject to the provisions of this section (16.280) of Lane Code must comply with Lane Code Chapter 15, Roads, except as provided below.

- (i) **Traffic Impact Analysis Requirements.** The County may require a traffic study prepared by a qualified professional to determine access, circulation, and other transportation requirements in conformance with LC 15.697.

**Exception:** Lane Code 15.697 does not apply to any development proposal that if approved will result in an increase of less than 50 peak hour automobile trips.

However, all developments must at a minimum provide a trip generation or debit letter to document how many trips are associated with the proposed use.

- (c) **Sanitary Sewer and Water Service Improvements.** The proposed use and development must not result in public health hazards or adverse environmental impacts that violate state or federal water quality regulations.

The proposed use and development must not exceed the carrying capacity of the soil or existing water supply resources. To address this requirement, factual information must be provided about any existing or proposed sewer or water systems for the site and the site's ability to provide on-site sewage disposal and water supply if a community water or sewer system is not available. Approval of an on-site sewage disposal system from the property approval authority must constitute adequate factual information to demonstrate compliance with sewer component of this standard.

When a community water or sewer system is proposed to provide service to a use or development, the following standards apply:

- (i) **Sewers and Water Mains Required.** Sanitary sewers and water mains must be installed to serve each new development and to connect developments to existing mains in accordance with the County's Sanitary Sewer Master Plan, Water System Master Plan, and the applicable construction specifications. When streets are required to be stubbed to the edge of the subdivision, sewer and water system improvements must also be stubbed with the streets, except as may be waived by the County Engineer.
  - (ii) **Sewer and Water Plan Approval.** Development permits for sewer and water improvements will not be issued until the County Engineer has approved all sanitary sewer and water plans in conformance with County standards.
  - (iii) **Over-Sizing.** The County may require as a condition of development approval that sewer, water, and/or storm drainage systems serving new development be sized to accommodate future development within the area as projected by the applicable Water, Sewer, and/or Storm Drainage Master Plan, provided that the County may grant the developer credit toward any required system development charge for the same.
  - (iv) **Inadequate Facilities.** Development permits may be restricted by the County where a deficiency exists in the existing water or sewer system that cannot be rectified by the development and which if not rectified will result in a threat to public health or safety, surcharging of existing mains, or violations of state or federal standards pertaining to operation of domestic water and sewerage treatment systems.
- (d) **Stormwater Management Requirements**
- (i) **General Provisions.** The County will issue a development permit only where adequate provisions for stormwater and flood water runoff have been made in conformance with the stormwater management requirements set forth in this subsection 16.280(d).

Connections to drainage facilities within the County right-of-way must be authorized through facility permits issued by the Director in accordance with ORS 374.305 through 374.340.

- (ii) **Definitions.** For the purposes of this Section and the Stormwater Management Manual, the following definitions apply:
- (aa) **Base Flood.** The flood having a one percent chance of being equaled or exceeded in any given year. Also referred to as the "100-year flood."
  - (bb) **Biofiltration.** Deliberate filtering of sediments and other pollutants from stormwater runoff by directing flow through a vegetated area.
  - (cc) **Channel Maintenance.** Periodic removal of debris, sediment, vegetation, litter and other material within the bed or banks of a stream or channel recognized as part of the city's stormwater drainage system, and performed by the city or in accordance with county policy.
  - (dd) **Channelize, Channelizing.** Human alteration of the bed or banks of a natural stream or river to maintain or increase its conveyance or capacity characteristics without maintaining its natural character, typically by straightening its course, increasing its depth and removing obstructions in the bed or on the banks.
  - (ee) **Constructed Wetlands.** A facility that exhibits wetland characteristics but was constructed for the express purpose to perform a utility need, such as a sedimentation pond, and is not eligible for mitigation credit or subject to the jurisdictional requirements of federal and state wetland law.
  - (ff) **Easement of Record.** A valid easement that is recorded and on file at the Lane County Recorder's office.
  - (gg) **Enhancement.** To increase or improve natural values in one or more of the following ways:
    - Increasing the wildlife habitat value by increasing the supply and diversity of natural food sources throughout the year, increasing the diversity and duration of water features throughout the year or increasing the diversity in size and structure of plants.
    - Improving water quality by reducing the amount of pollutants entering the water or removing pollutants already in the water.
    - Improving the natural character by encouraging and allowing natural vegetation to grow in natural patterns according to soil and water conditions.
    - Removing litter, refuse and unnatural fill.
    - Improving the capacity of the area to contain, detain or filter stormwater runoff.
  - (hh) **Flood, or Flooding.** A general and temporary condition of partial or

complete inundation of normally dry land areas from:

- The overflow of inland or tidal waters; or
  - The unusual and rapid accumulation of runoff of surface waters from any source.
- (ii) **Flood control design storm.** A theoretical storm for evaluating the capacity of the storm drainage system and designing improvements for the required level of protection, in accordance with the Stormwater Management Manual.
- (jj) **Flood Insurance Rate Map (FIRM).** The official map on which the Federal Insurance Administration has delineated both the areas of special flood hazards and the risk premium zones applicable to the community.
- (kk) **Flood Insurance Study.** The official report provided by the Federal Insurance Administration that includes flood profiles, the Flood Boundary-Floodway Map, and the water surface elevation of the base flood.
- (ll) **Floodway.** The channel of a river or other watercourse and the adjacent land areas designated as a floodway by the Federal Emergency Management Agency.
- (mm) **Flow control facility.** Any structure or drainage device that is designed, constructed, and maintained to collect, retain, infiltrate, or detain surface water runoff during and after a storm event for the purpose of controlling post-development water quantity leaving the development site.
- (nn) **Goal 5 Water Resource Site.** The resource site as identified in the Goal 5 Water Resources Conservation Plan. For riparian corridor and upland wildlife habitat sites, the Goal 5 Water Resource Site includes the stream and riparian areas that may extend beyond applicable conservation setbacks. Wetland sites include only the wetland, itself.
- (oo) **Grassy Swales.** Shallow ditches lined with grass or other vegetation for the purpose of filtering sediments and other pollutants from stormwater runoff.
- (pp) **Impervious surface/area.** Any surface area that causes water to run off the surface in greater quantities or at an increased rate of flow from conditions pre-existing to development. Types of impervious surface include, but are not limited to, rooftops, asphalt and concrete parking lots, driveways, roads, sidewalks, and pedestrian plazas. *Note:* Slatted decks are considered pervious. Gravel surfaces are considered pervious unless they cover impervious surfaces or are compacted to a degree that causes their runoff coefficient to exceed 0.8.
- (qq) **Natural Drainageways.** Natural rivers, streams, channels, creeks, or

other areas that naturally convey stormwater runoff or portions thereof that have not been channelized, and which retain a predominantly natural character.

- (rr) **Natural Functions and Values.** Characteristics of a site that contribute to the healthy and effective functioning of natural processes on the site, along with the contribution made by the site to the healthy and effective functioning of the larger natural resource system of which the site is a part; including but not limited to improvement of water quality, provision of food, water and cover for wildlife, storage capacity for flood waters, protection against erosion, sediment removal, fisheries habitat, and groundwater recharge or discharge.
- (ss) **Natural Resource Area.** The area within the mapped boundaries of any locally inventoried wetland, pond, stream, channel, river, lake or upland wildlife habitat area.
- (tt) **Oil control facility.** Any structure or drainage device that is designed, constructed, and maintained to remove oil and grease from storm runoff.
- (uu) **Open Waterway.** A natural or human-made swale, creek, stream, open channel, ditch or other similar water feature, that has a defined and identifiable channel with slopes, that is predominantly of earthen material, and that has the specific function of conveying and/or storing stormwater runoff.
- (vv) **Property suspected or known to contain contaminants in the soil or groundwater.** Any real property where the presence of any hazardous substance or petroleum product indicates an existing release, past release, or threatened release of a hazardous substance or petroleum product into the ground, ground water, or surface water of the property.
- (ww) **Protected Wetland, Protected Natural Resource.** A wetland or other natural resource identified for protection in an adopted plan.
- (xx) **Stormwater Management Manual.** For purposes of this Section, the Stormwater Management Manual means the City of Eugene Stormwater Management Manual (April 2008 version), which has been adopted and incorporated by reference, and made applicable to the area subject to this Section 16.280.
- (yy) **Stormwater Management Facility.** Any structure or configuration of the ground that is used or, by its location, becomes a place where stormwater flows or is accumulated, including but not limited to, pipes, sewers, curbs, gutters, manholes, catch basins, ponds, open drainage ways, runoff control facilities, wetlands, and their accessories.
- (zz) **Water Features.** Permanent or intermittent bodies of water, including streams, ponds, rivers, lakes, drainage channels, open waterways and jurisdictional wetlands.

- (aaa) **Water Quality Design Storm.** A theoretical storm for estimating the amount of stormwater runoff to be treated. Facilities designed to store and treat a volume of stormwater must be sized in accordance with the Stormwater Management Manual.
- (bbb) **Wetland.** Any parcel or portion of a parcel which meets the state or federal definition of wetlands that are under the jurisdiction of state or federal laws.
- (ccc) **Wetland Boundary.** Any mapped wetland boundary produced by methods consistent with state and federal law and policy and for which a concurrence has been made in writing by the applicable state or federal agencies.
- (iii) **Stormwater Management Manual.** In order to implement applicable stormwater management requirements, Lane County has adopted and incorporated by this reference the April 2008 version of the City of Eugene Stormwater Management Manual as part of this Section 16.280 by Ordinance No. 13-2.

The Lane County Land Management Division will maintain and make available to the public copies of the Stormwater Management Manual.

- (iv) **Flood Control.**

  - (aa) **Purpose.** The purpose of Flood Control standards is to protect life and property from flood and drainage hazards by maintaining the capacity of the County's stormwater conveyance system through the establishment of destination regulations for stormwater runoff from development.
  - (bb) **Applicability and Exemptions.** Destination standards apply to all developments adding or redeveloping more than 1,000 square feet of impervious surfaces unless the replacement of more than 1,000 square feet of impervious surface is for purposes of maintenance or repair for the continuance of the current function on the development site.
  - (cc) **Standards.** Surface discharges from onsite facilities must be discharged to an approved drainage facility. On-site infiltration is the preferred stormwater destination for all developments. Stormwater drainage facilities must be designed and constructed according to adopted plans and policies, and in accordance with the stormwater destination provisions and the facility design requirements set forth in the Stormwater Management Manual. Stormwater management must avoid a net negative impact on nearby streams, wetlands, groundwater and other water bodies. All local, state, and federal permit requirements related to implementation of stormwater management must be met by the owner/operator prior to facility use.
  - (dd) **Underground Injection Control Systems.** Stormwater runoff disposed

of in underground systems is also regulated through the federal Underground Injection Control (UIC) program under Part C of the Safe Drinking Water Act (42 U.S.C. § 300, Chapter 6A, Subchapter XII) and Oregon Administrative Rule Chapter 340, Section 044. To utilize Underground Injection Controls for stormwater management the owner/operator must obtain authorization from the Oregon Department of Environmental Quality prior to facility use.

THIS SPACE INTENTIONALLY LEFT BLANK



(v) **Stormwater Pollution Reduction.**

- (aa) **Purpose.** The purpose of Stormwater Pollution Reduction standards is to reduce the impacts of development on water quality by providing standards for the capture and treatment of stormwater runoff from development.
- (bb) **Applicability and Exemptions.** Water Quality standards apply to all developments adding or redeveloping more than 1,000 square feet of impervious surfaces unless the replacement of more than 1,000 square feet of impervious surface is for purposes of maintenance or repair for the continuance of the current function on the development site.
- (cc) **Standards.** The quality of the stormwater leaving the site after development must be equal to or better than the quality of the stormwater leaving the site before development, as much as is practicable based upon the following:
- (A) Applications must include pollution reduction facilities selected from the Stormwater Management Manual as follows:
- (i) For land use applications for undeveloped land, the selected pollution reduction facilities must treat all the stormwater runoff from the development site that will result from the water quality design storm;
  - (ii) For land use applications that change or add development to an already developed site, the selected pollution reduction facilities must treat the stormwater runoff from all added and replaced impervious surface that will result from the water quality design storm;
  - (iii) For development permit applications, the selected pollution reduction facilities must treat all stormwater runoff from all new or replaced impervious surface, or an equivalent on-site area, that will result from the water quality design storm;
- (B) All pollution reduction facilities must be sited, designed and constructed according to the pollution reduction provisions and the facility design requirements set forth in the Stormwater Management Manual.

(vi) **Stormwater Flow Control.**

- (aa) **Purpose.** The purpose of Stormwater Flow Control standards is to protect waterways from the erosive effects of increases in stormwater runoff peak flow rates and volumes resulting from development.
- (bb) **Applicability and Exemptions.** Flow Control standards apply to all

developments adding or redeveloping more than 1,000 square feet of impervious surfaces unless the replacement of more than 1,000 square feet of impervious surface is for purposes of maintenance or repair for the continuance of the current function on the development site.

(cc) **Standards.** The quantity and flow rate of stormwater leaving the site after development must be equal to or less than the quantity and flow of stormwater leaving the site before development, as much as practicable, based on the following criteria:

(A) Applications must demonstrate, using methodology in the Stormwater Management Manual, that peak rates of flow delivered to an existing open waterway will not increase during storms larger than the water quality design storm and smaller than the flood control design storm as a result of the development that is the subject of the application;

(B) All facilities to control the rate of stormwater runoff must be sited, designed and constructed according to the flow control provisions and the facility design requirements set forth in the Stormwater Management Manual. Flow control facilities must be designed using one of the methodologies outlined in the Stormwater Management Manual.

(vii) **Stormwater Oil Control.**

(aa) **Purpose.** The purpose of Stormwater Oil Control standards is to protect the County's stormwater system from oil and grease from stormwater runoff of impervious surface areas on properties that produce high concentrations of these pollutants.

(bb) **Applicability.** Oil control standards apply to:

(A) All new commercial and industrial development with parking lots that store wrecked or impounded vehicles; or

(B) Any development that would result in an expected daily traffic count greater than one hundred vehicles per 1,000 square feet of gross building area, based on the most recent version of The Institute of Transportation Engineers' Trip Generation Manual; or

(C) Any development that would result in 100 or more off-street parking spaces.

(cc) **Standards.** All oil control facilities must be sited, designed and constructed according to the oil control provisions and the facility design requirements set forth in the Stormwater Management Manual.

(viii) **Stormwater Source Controls.**

- (aa) **Purpose.** The purpose of Stormwater Source Control standards is to prevent stormwater pollution by eliminating pathways that may introduce pollutants into stormwater.
- (bb) **Applicability and Exemptions.** Except as exempted below and except when the source control would duplicate source controls required by a state or federal permit obtained by the applicant, source control standards apply to all land use applications, development permits and tenant improvements that result in any of the defined site uses or characteristics listed in below.
- (A) Fuel dispensing facilities and surrounding traffic areas where vehicles, equipment, or tanks are refueled on the premises. A fuel dispensing facility is the area where fuel is transferred from bulk storage tanks to vehicles, equipment, and/or mobile containers. Exempt from this subsection are:
- (i) Propane tanks.
  - (ii) Fuel dispensing areas generally used to service oversized equipment, for example cranes, that cannot maneuver under a roof or canopy.
  - (iii) Existing fueling areas where scope of work is limited to a new canopy installation over an existing fuel pad that is not being upgraded, an underground tank replacement for compliance with state regulations, or the replacement of a fuel pump on an existing fuel pad that is not being upgraded.
- (B) Exterior storage of liquid materials, for example chemicals, food products, waste oils, solvents, process wastewaters, or petroleum products in aboveground containers, in quantities of 50 gallons or more, including permanent and temporary storage areas. Exempt from this subsection are underground storage tanks or installations requiring a Water Pollution Control Facility (WPCF) permit and containers with internal protections (such as double-walled containers).
- (C) All facilities that store solid waste. A solid waste storage area is a place where solid waste containers, including compactors, dumpsters, and garbage cans, are collectively stored. Solid waste storage areas include, areas used to collect and store refuse or recyclable materials collection areas. Exempt from this subsection are solid waste storage areas for one and two family dwelling and areas used for the temporary storage of wood pallets or cardboard.
- (D) Developments that stockpile or store high-risk or low-risk bulk materials in outdoor containers, as the terms “high risk” and “low risk” are in the Stormwater Management Manual. Exempt from this subsection are:
- (i) Materials which have no measurable solubility or mobility in water and no hazardous, toxic or flammable properties.
  - (ii) Materials which exist in a gaseous form at ambient temperature.
  - (iii) Materials, except for pesticides and fertilizers, that are contained in a manner that prevents contact with stormwater.

- (E) Developments proposing the installation of new material transfer areas as defined in the Stormwater Management Manual, or structural alterations to existing material transfer areas, such as access ramp re-grading and leveler installations. Exempt from this subsection are areas used only for mid-sized to small-sized passenger vehicles and restricted by lease agreements or other regulatory requirements to storing, transporting or using materials that are classified as domestic use, for example, primary educational facilities (elementary, middle or high schools), buildings used for temporary storage and churches.
- (F) All development with a designated equipment or vehicle washing or steam cleaning area, including smaller activity areas such as wheel-washing stations. Exempt from this subsection are:
  - (i) Washing activity areas generally used to service oversized equipment than cannot maneuver under a roof or canopy, for example cranes and sail boats.
  - (ii) Evaporation unit installed as part of a wash recycling system are exempt from the wastewater connection requirement.
  - (iii) One and two family dwelling sites.

Development that is intended for the storage of 10 or more fleet vehicles must include a designated vehicle washing area.

- (G) All development projects that disturb property suspected or known to contain contaminants in the soil or groundwater.
- (H) All development with new covered vehicle parking areas, or existing parking structures that are being developed. Exempt from this subsection are single-level canopies, overhangs and carports.
- (cc) **Standards.** All source controls must be designed and constructed according to the source control provisions set forth in the Stormwater Management Manual.
- (dd) **Enforcement.** Failure to construct, operate and maintain source controls when a land use application, development permit or tenant improvement has resulted in a defined site use or characteristic listed above is subject to enforcement in accordance with Lane Code.

(ix) **Dedication of Stormwater Easements.**

- (aa) **Purpose.** The purpose of Dedication of Stormwater Easements is to ensure that County maintained stormwater management facilities designed and constructed in accordance with adopted policies and the Stormwater Management Manual can be accessed by the County for routine and/or emergency maintenance to protect life and property from flood and drainage hazards, ensure that water quality is protected, and to ensure that waterways in the headwaters area are protected from the erosive effects of runoff.
- (bb) **Applicability.** Stormwater easement standards apply to all land use applications and development permits that result in the construction of a County maintained

Stormwater Management Facility.

(cc) **Standards.** The applicant must dedicate public easements approved by the County over County maintained stormwater management facilities provided the County makes findings to demonstrate consistency with constitutional requirements. The conveyance of ownership or dedication of easements may be required in any of the following circumstances:

- (A) Except for areas on the County's acknowledged Goal 5 inventory, where the subject property in the proposed development is or will be periodically subject to accumulations of surface water or is traversed by any open drainage way, headwater, stream, creek, wetland, spring, or pond, including those not maintained by the city which drain onto or from city-owned property or into city maintained facilities.
- (B) For areas on the County's acknowledged Goal 5 inventory, where the subject property in the proposed development is or will be periodically subject to accumulations of surface water or is traversed by any water course or channel.
- (C) Where necessary to extend public drainage facilities and services to adjoining undeveloped property.
- (D) To provide necessary drainage from the public right-of-way.
- (E) Where the County has accepted functional maintenance responsibility for pollution reduction and/or flow control facilities.

(x) **Stormwater Operation and Maintenance.**

(aa) **Purpose.** The purpose of Stormwater Operation and Maintenance standards is to ensure that stormwater management facilities designed and constructed in accordance with the Stormwater Management Manual are operated and maintained in a manner that protects life and property from flood and drainage hazards, protects water quality, and protects the waterways from the erosive effects of runoff.

(bb) **Applicability.** Operation and maintenance standards apply to all facilities designed and constructed in accordance with the Stormwater Management Manual.

(cc) **Standards**

- (A) Unless the County accepts the responsibility to operate and maintain a stormwater facility, all stormwater management facilities must be privately operated and maintained.
- (B) All stormwater facilities must be operated and maintained in accordance with Lane Code and the Stormwater Management Manual.



- (i) **Provision.** The developer or applicant must make arrangements with the County, the applicable zone, and each utility franchise for the provision and dedication of utility easements necessary to provide full services to the development. The County's standard width for public main line utility easements is determined by the County Engineer.
- (ii) **Recordation.** As determined by the County Engineer, all easements for sewers, stormwater management, water quality facilities, water mains, electric lines, or other public utilities must be recorded with the final plat. See subsection (6), Site Design Review, and Lane Code Chapter 13, Land Divisions.

THIS SPACE INTENTIONALLY LEFT BLANK

(g) **Construction Plan Approval and Assurances**

- (i) **Plan Approval and Permit.** No public improvements, including sanitary sewers, storm sewers, streets, sidewalks, curbs, lighting, parks, or other requirements may be undertaken until the plans have been approved by the County, permit fee paid, and permit issued. The permit fee is required to defray the cost and expenses incurred by the County for construction and other services in connection with the improvement. The permit fee is set by the County.
- (ii) **Performance Guarantee.** The County may require the developer or subdivider to provide bonding or other performance guarantees to ensure completion of required public improvements. See subsection (6), Site Design Review, and Lane Code Chapter 13, Land Divisions.

(h) **Installation**

- (i) **Conformance Required.** Improvements installed by the developer either as a requirement of these regulations or at his/her own option, must conform to the requirements of this Chapter, approved construction plans, and to improvement standards and specifications adopted by the County.
- (ii) **Commencement.** The County must be notified in advance in writing before any work begins.
- (iii) **Resumption.** If work is discontinued for more than one month, the County must be notified in writing before work is resumed.
- (iv) **County Inspection.** Improvements must be constructed under the inspection and to the satisfaction of the County. The County may require minor changes in typical standards and specifications, and details if unusual conditions arising during construction warrant such changes in the public interest. Modifications to the approved design requested by the developer may be subject to review as a modification of approval and/or conditions of approval. Any monuments that are disturbed before all improvements are completed by the subdivider must be replaced prior to final acceptance of the improvements.
- (v) **Engineer's Certification and As-Built Plans.** A registered engineer must provide written certification in a form required by the County that all improvements, workmanship, and materials are in accord with current and standard engineering and construction practices, conform to approved plans and conditions of approval, and are of high grade, prior to County acceptance of the public improvements, or any portion thereof, for operation and maintenance. The developer's engineer must also provide two set(s) of "as-built" plans, in conformance with the County Engineer's specifications, for permanent filing with the County. *(Revised by Ordinance No. 13-2, Effective 7.4.13; 20-05, 6.16.20)*



PAGES 16-645 THROUGH 16-750  
ARE RESERVED FOR FUTURE EXPANSION